



ALAGAPPA UNIVERSITY

[Accredited with 'A+' Grade by NAAC (CGPA:3.64) in the Third Cycle
and Graded as Category-I University by MHRD-UGC]

(A State University Established by the Government of Tamil Nadu)

KARAIKUDI – 630 003



Directorate of Distance Education

M.Sc. [Zoology]

II - Semester

350 24

PRACTICAL

LAB II : DEVELOPMENT BIOLOGY

AND EVOLUTION, GENETICS AND

MICROBIOLOGY

Author:

Dr. Ngangbam Sarat Singh, Assistant Professor, Department of Zoology, Dr. Sarvepalli Radhakrishnan Government Arts College, Yanam, Puducherry (UT)

"The copyright shall be vested with Alagappa University"

All rights reserved. No part of this publication which is material protected by this copyright notice may be reproduced or transmitted or utilized or stored in any form or by any means now known or hereinafter invented, electronic, digital or mechanical, including photocopying, scanning, recording or by any information storage or retrieval system, without prior written permission from the Alagappa University, Karaikudi, Tamil Nadu.

Information contained in this book has been published by VIKAS® Publishing House Pvt. Ltd. and has been obtained by its Authors from sources believed to be reliable and are correct to the best of their knowledge. However, the Alagappa University, Publisher and its Authors shall in no event be liable for any errors, omissions or damages arising out of use of this information and specifically disclaim any implied warranties or merchantability or fitness for any particular use.



VIKAS®

Vikas® is the registered trademark of Vikas® Publishing House Pvt. Ltd.

VIKAS® PUBLISHING HOUSE PVT. LTD.

E-28, Sector-8, Noida - 201301 (UP)

Phone: 0120-4078900 • Fax: 0120-4078999

Regd. Office: 7361, Ravindra Mansion, Ram Nagar, New Delhi 110 055

• Website: www.vikaspublishing.com • Email: helpline@vikaspublishing.com

Work Order No. AU/DDE/DE1-291/Preparation and Printing of Course Materials/2018 Dated 19.11.2018 Copies - 500

PRACTICAL
LAB II : DEVELOPMENT BIOLOGY AND EVOLUTION,
GENETICS AND MICROBIOLOGY

Syllabi

DEVELOPMENTAL BIOLOGY AND EVOLUTION

1. Frog: Egg, blastula and yolk plug stage.
2. Chick: Egg, 24 hrs, 36 hrs, 48 hrs, 72 hrs and 96 hrs developmental stages.
3. Placental types in Mammals.
4. Animals of evolutionary importance.
5. Analogous and homologous organs.
6. Fossils.
7. Mimicry and coloration.

GENETICS

1. Klinefelter's Syndrome, Turner's Syndrome, Down's Syndrome and Cri- Du – Chat.
2. Pedigree analysis using charts and data.
3. Human karyotyping and chromosomal abnormalities.
4. Hardy-Weinberg law & Calculation of gene frequencies for dominant and recessive traits.

MICROBIOLOGY

1. Enumeration of Bacteria and Fungi.
 2. Pure culture and preservation of Bacteria.
 3. Gram Staining and Negative Staining.
 4. Motility of Bacteria.
 5. Hydrolysis of Starch, Gelatin and Protein.
 6. Antibiotic susceptibility test.
-

INTRODUCTION

NOTES

Evolutionary developmental biology is a specialized field of biology that compares the developmental processes of different organisms to conclude the ancestral relationships between them and how developmental processes evolved. Principally, the evolutionary developmental biology is concerned with the study that how changes in embryonic development takes place during single generations and the evolutionary changes that occur between generations.

Earlier the zoologists did not know how embryonic development was controlled at the molecular level. Charles Darwin theory of evolution describes the significance that how the development ‘Embryology’ helps in understanding the evolutionary process. Typically, the recombinant DNA technology eventually brought embryology together with molecular genetics.

Genetics is a branch of biology that is concerned with the study of genes, genetic variation, and heredity in organisms. Gregor Mendel, a scientist and Augustinian friar, discovered genetics and studied the ‘trait inheritance’, patterns in the way traits are handed down from parents to offspring. The modern genetics has expanded beyond inheritance and includes the study and analysis of the functions and behaviour of genes. Characteristically, the gene structure and function, variation, and distribution are considered within the context of the cell, the organism, such as dominance, and within the context of a population. Genetics has given rise to a number of subfields, including epigenetics and population genetics.

Microbiology is the study of microorganisms or microscopic organisms, those being unicellular (single cell), multicellular (cell colony), or acellular (lacking cells), such as bacteria, viruses, archaea, fungi and protozoa. Microbiology comprehends numerous sub-disciplines including virology, parasitology, mycology and bacteriology. Microorganisms and their activities are extremely significant to virtually all processes on Earth because they affect every aspect of our lives – they are in us, on us and around us. These microbes have key roles in nutrient cycling, biodegradation/biodeterioration, climate change, food spoilage, the cause and control of disease, and biotechnology. Due to their versatility, microbes are used for making life-saving drugs, the manufacture of biofuels, cleaning up pollution, and producing/processing food and drink.

This book, *Developmental Biology and Evolution, Genetics and Microbiology*, deals with the practical aspects of qualitative and quantitative analysis of the techniques used in the laboratory. The various disciplines of developmental biology and evolution, genetics and microbiology includes fundamental research on the epigenetics, population genetics, biotechnology, biochemistry, physiology, cell biology, ecology, evolution and clinical aspects of microorganisms, including the host response to these agents.

GENERAL INSTRUCTIONS AND LABORATORY ETHICS

*Practical
Lab II : Development
Biology and Evolution,
Genetics and Microbiology*

GENERAL INSTRUCTIONS

1. The students while coming to the laboratory for the practical class work, must check that they have the essential materials with them for the practical, namely practical notebook, pencil, pencil eraser, sharpener, scale, brush and a complete set of dissecting instruments.
2. The instruments should be sharp and according to the requirements.
3. To come prepared with the work you are supposed to do in the laboratory.
4. To keep your instruments, practical notebook and seat well-arranged and tidy.
5. Do not encourage the habit of lending either to or from your class fellows. Bring all the essential requirements of the day for the practical laboratory.
6. Listen carefully to the instructions given by your teacher before starting the work.
7. Discuss all your difficulties with your teacher and do not consult your class fellows for any help.
8. Never rub your pencil either on the floor or on the top of the working table. Use a sharpener for the work.
9. Clean the working table and arrange your seat before leaving the laboratory.
10. Maintain complete silence in the laboratory.

NOTES

STUDENT'S BELONGINGS OR EQUIPMENT FOR LAB WORK

The students while coming to the laboratory for the practical work are required to bring certain compulsory equipment. However, it is not possible to list all that is required, but the following list is considered necessary:

1. The practical book or laboratory manual of the practical and practical record book.
2. The drawing pencil to draw or sketch the diagram of specimens, slides or equipment.
3. Pencil sharpener, pencil eraser and measuring scale.
4. Well maintained dissecting box with following instruments: scalpels, scissors, forceps, dissecting needles, blowpipe, and one edged safety razor or blade.
5. Brush, dropper (one), hand lens, a piece of clean cloth and dissecting pins or T pins.

Note: Do not mind bringing all these things regularly as you do not know when you may need them.

NOTES

INSTRUCTION ABOUT USING MICROSCOPE

Students while using microscope to observe permanent or temporary mount slides should keep in mind the following points:

1. The microscope should always be placed on a flat surface in a well-lit area.
2. Place the slide below the objective lens on the stage of the microscope. While doing so, make sure that the objective lens does not touch the slide.
3. Adjust the reflective mirror so that the slide is exposed to sufficient light.
4. Rotate the nosepiece to the lowest power (either 4X or 10X). It is very important to start with the lowest magnification in order to get proper focus. Higher magnification can be used once the focus is set.
5. Adjust the stage up and down as well as left and right to bring the specimen under the objective lens.
6. Focus the slides by rotating the coarse focus knob (the larger of the two knobs on the side of the microscope).
7. Once the slide is under focus, adjust the fine knob for fine focussing to obtain better clarity.
8. If required, increase the magnification of the objective lens by rotating the nosepiece to the next higher magnification and then adjust the focus.

INSTRUCTIONS TO STUDY AND DRAW THE MUSEUM SPECIMENS

1. Before leaving home for Zoology practical laboratory, check that you are equipped with a Zoology Practical Exercise Book, H.B. pencil, pencil sharpener, pencil eraser (good quality rubber) and a piece of soft cloth.
2. Try to obtain advance information about the slides or museum specimens to be drawn so that you come prepared for their study.
3. Special care should be taken to give a very correct proportion of the dimensions (length and breadth) of the slides or specimen.
4. Usually, draw only one diagram on a page and write their respective comments on the opposite page.
5. Only line diagrams should be drawn.
6. The shading should be avoided as far as possible.

7. Each diagram must be fully labelled with the help of Lab Manual.
8. The labelling should be horizontal and clear.

PRACTICAL NOTEBOOK (PRACTICAL RECORD BOOK)

1. The practical notebook should be neat, clean and up-to-date.
2. Write the date on the left-hand corner of the page of the notebook and details of the work on the top in the centre.
3. The diagrams should be correctly drawn and well-labelled.
4. The diagrams of all museum specimens, slides and dissections should be drawn and comments on all should be written.

STUDY OF SPECIMENS, SLIDES AND TIPS FOR SPOTTING

During the practical examination, the spotting is a very important exercise to obtain marks and merit. Students often face difficulty in spotting because of the lack of proper understanding of basic concepts and the method of commenting on a spot. Here are a few tips for good spotting.

1. First and foremost identify the spot along with the spot number.
2. Draw a well-labelled line diagram of the spot.
3. The important comments can be highlighted in the diagram.
4. The comments should be short and precise.
5. Always mention the special features of the spotting specimen.

MOUNTING AND PREPARATION OF PERMANENT SLIDES

While making the permanent slides (mountings) the following instructions should be strictly followed.

1. Never keep your mounting specimen material for less or more time than the desired time in an alcoholic grade or stain.
2. Keep the specimen material for slightly more time in 90% alcohol and absolute alcohol for complete dehydration.
3. Ensure that complete dehydration is done after putting the specimen material in absolute alcohol. To ensure that the specimen material is completely dehydrated put it in either Xylol or Benzene. If it gives turbidity with Xylol, then dehydrate it again.
4. Do the dehydration in closed specimen tubes or in covered cavity blocks.
5. Always use a brush and never the forceps for holding the mounting specimen material.
6. Put the required amount of Canada Balsam or D.P.X on the slides for mounting.

Note: Excess of Canada Balsam or D.P.X makes the slide dirty.

NOTES

DEVELOPMENTAL BIOLOGY AND EVOLUTION

NOTES

Experiment #1: To study the developmental stages of Frog: Egg, Blastula and Yolk Plug Stage.

Objective: To identify and describe the different developmental stages in frog development from a fertilized egg to gastrula from permanent slides by observing under the microscope.

Introduction: Frogs are amphibians which lay their eggs in water. A single female frog can lay up to 4000 eggs in cluster known as “**egg masses**”. For example: *Rana pipiens* lay around 2500 eggs, while 20,000 in case of the bullfrog, *Rana catesbiana*. In most species of amphibians, fertilization is external. In this case, the male frog grabs the female’s back and fertilizes the eggs as they are released from a female. The eggs are covered by jelly layers which protect and adheres the eggs to nearby plants or substratum and anchor the eggs. Other species may release their eggs without any support and make them float in the aquatic environment.

Frogs eggs are **mesolecithal**, i.e., contains moderate amount of yolk which are concentrated at one end of the egg. Hence, it is **telolecithal**. All the development stages of frogs occur in the aquatic environment.

Materials Required: Prepared permanent microscopic slides of Frog’s Embryo, Compound microscope.

FROG’S EGG

A. **Unfertilized Egg:** The life of most of the frogs depends upon the ecology and temperature of the aquatic and terrestrial environment where they live. Therefore, they bear the seasonal lifecycle, i.e., gametogenesis and fertilization are seasonal events. In the presence of favourable conditions (photoperiod and temperature), pituitary gland secrete hormone which stimulate the ovary to make estrogens and progesterone. Estrogen signals the liver to secrete the yolk protein and then this protein reaches into the vegetal hemisphere of the enlarging eggs (mesolecithal type of egg) in the ovary through blood.

1. The **egg** or **ovum** is surrounded and covered by following three distinct layers:
 - a. **Innermost Plasma Membrane:** The innermost plasma membrane is secreted by the egg itself.
 - b. **Middle Vitelline Membrane:** The middle vitelline membrane is the intermediate layer of mucopolysaccharide secreted by follicular cells of the ovary.

NOTES

- c. **Jelly Coat:** The jelly coat is the gelatinous, tertiary egg membrane of albumen consisting of 3-4 gelatinous rings which are secreted by the wall of the oviduct.
2. The jelly coat protects the eggs and also attracts and activates sperm.
3. The **egg cytoplasm (ooplasm)** has 2 regions, viz., **peripheral cortex** and **central endoplasm**.
4. The **cortex** is **granular**.
 - a. It shows presence of cortical granules and dark brown pigment granules.
 - b. Cortical granules are arranged in a layer close to the plasma membrane.
5. The **endoplasm** contains numerous plates like structures called as yolk platelets.
6. The egg shows well-marked polarity.
7. On one side is the **animal pole** containing nucleus. The animal pole appears darker.
8. **Vegetal pole** containing yolk granules occupy the other half of the egg. It is yellowish or whitish (lighter) in colour.

Figure 1 illustrates the unfertilized egg of frog.

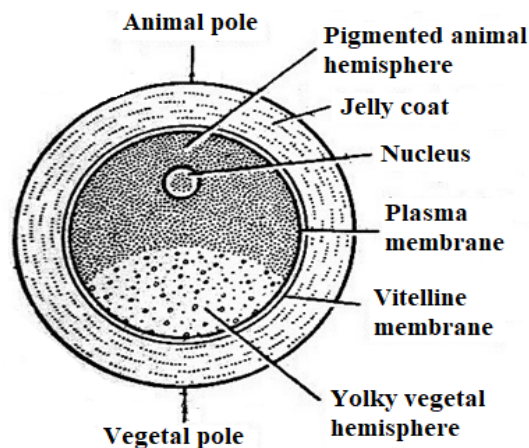

Fig. 1. Unfertilized Egg of Frog

B. Fertilized Egg: The eggs are in the Metaphase II of meiotic division when it is laid by the female. The fertilization of egg by sperm activates the egg to complete its meiotic division and results in the formation of second polar body.

1. The polar bodies are present near the animal pole.
2. During fertilization, the pronucleus of both the egg and the sperm fuse in the egg cytoplasm and formation of the diploid zygotic nucleus occur in the animal hemisphere.

NOTES

3. Soon after fertilization, the cortical granules secrete its contents into the inter-membranous space lifting the vitelline membrane from the egg. This forms the **fertilization membrane** which prevents polyspermy.
4. A grey crescent is visible opposite the point of entry of the sperm at the margin between the animal and vegetal hemisphere, largely in the animal hemisphere. It is more lightly pigmented than the animal hemisphere. The grey crescent later forms the posterior and dorsal side of the embryo.
5. Fertilization also results in the activation of enzymes necessary for the beginning of cleavage and development.

Figure 2 illustrates the fertilized egg of frog.

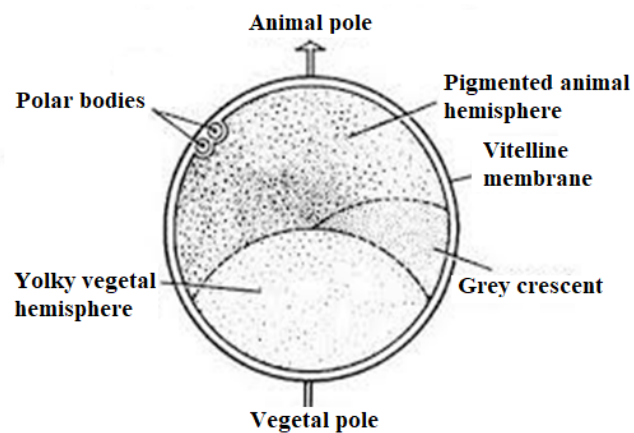

Fig. 2. Fertilized Egg of Frog

FROG'S EMBRYO: BLASTULA

After fertilization, the zygote undergoes series of mitotic cell division and form large number of cells. This process of rapid mitotic cell division whereby the enormous volume of egg cytoplasm is divided into numerous smaller, nucleated cells is called cleavage. The cleavage stage cells are called blastomeres. Cleavage is generally characterized by rapid, successive cell division without growth i.e. cytoplasmic volume does not increase.

The frog's embryo undergoes **radial, unequal holoblastic cleavage** in which the first two cleavage planes are meridional passing through the animal-vegetal pole. This leads to the formation of four equal sized blastomeres. However, due to presence of yolk in the vegetal hemisphere, the third cleavage plane is horizontal and not equatorial. This results in formation of four smaller blastomeres at the animal hemisphere lying exactly over four larger vegetal hemisphere cells. The smaller animal hemisphere cells are known as **micromeres** while the larger vegetal hemisphere cells are called **macromeres**.

As the cleavage continues to divide the embryo into increasing number of blastomeres, a fluid-filled cavity appears within the blastomeres. This fluid-filled cavity is called **blastocoele** and the embryo at this stage is known as the **blastula**.

NOTES

1. Due to unequal holoblastic cleavage, frog blastula is also an **Amphiblastula**, i.e., formed of two types of structurally different blastomeres – micromeres and macromeres.
 - a. Micromeres are small darker blastomeres present in the animal hemisphere.
 - b. Macromeres are large grayish yolk laden blastomeres present in the lower vegetal hemisphere.
2. Since there is no growth of cells during cleavage, the blastula is about the same size as the egg before it began to divide.
3. The blastocoele is eccentric and present in the animal hemisphere.
4. During the early blastula stage, the roof of the blastocoele is formed by single layer of micromeres which later becomes multilayered in the late blastula stage.
5. The multilayered macromeres form the floor of the blastocoele.
6. As the cells multiply, those in the highest part of the roof of the blastocoele migrate toward the equator so that the roof becomes thinner and the lateral wall becomes thicker. The thicker lateral wall, which exhibits rapid cell proliferation, is called the **germ ring**.
7. Formation of the definitive blastula characteristic of each species terminates cleavage and initiates gastrulation.

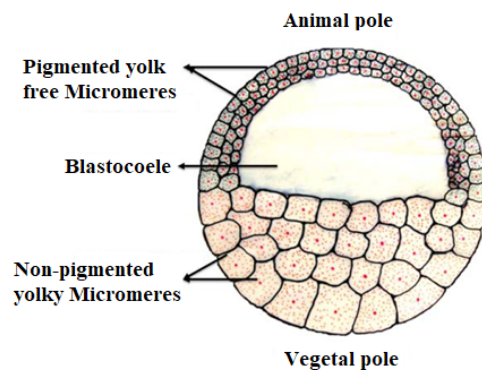

Fig. 3. Vertical Section of Blastula of Frog

FROG'S EMBRYO: YOLK PLUG STAGE

Gastrulation, the process of formation of three germ layers is brought about by several types of morphogenetic movements taking place at the same time.

NOTES

In frog's embryo, the first indication of gastrulation is the appearance of a small groove on the surface of the blastula just ventral to the grey crescent. This slit is the beginning of the **blastopore** and represents the area where the cells forming the surface of the blastula move toward the inside to form the primary germ layers. In the early gastrula, the blastopore is visible as an indentation near the vegetal pole.

As the gastrulation progress, cells begin to move inward over the ventral lip, and the blastopore becomes a round opening. Movements of cells inward result in the formation of the gastrocoele (archenteron) which expand dorsally toward the animal pole obliterating blastocoele. The micromeres grow over the macromeres and cover more than half of the embryo.

During the late gastrula stage or the yolk plug stage,

1. The embryo changes its shape from spherical to oval.
2. The micromeres have grown over the macromeres and cover their major portion.
3. Micromeres have grown into the blastocoels.
4. The blastocoels is highly obliterated and reduced to a narrow canal due to development of archenteron.
5. Invaginations have grown into a well-formed spacious cavity – the gastrocoel or archenteron.
6. Blastopore is present in the dorso-lateral wall.
7. The dorsal lip of blastopore is formed by the invaginating micromeres.
8. The ventral lip of blastopore is also formed in similar fashion on the ventro-lateral side.
9. Most cells have finished their movement to the inside, and the yolk laden macromeres which form the floor of the archenteron project out from the blastopore in the form of **yolk-plug**.
10. Embryo in the late gastrula stage consists of three different layers:
 - a. **Ectoderm or Outer Layer:** It is formed of micromeres and covers the whole embryo. It will give rise to epidermis, cutaneous glands, nervous system, eye parts and lining of mouth cavity and cloaca.
 - b. **Endoderm or Inner Layer:** It is formed of yolk laden macromeres lining the floor of the archenteron. It will form the lining of alimentary canal, liver, pancreas, lung urinary bladder and primordial germ cells.
 - c. **Mesoderm or Middle Layer:** This is formed by the separation of in-growing micromeres and cover the roof and lateral side of the archenteron. It will give rise to the musculature, connective tissue, vascular system, genital organs, excretory organs, skeleton and notochord.

11. The ectodermal cells directly overlying the archenteron roof at the yolk plug gastrula stage constitute the neural ectoderm which gives rise to neural tube.

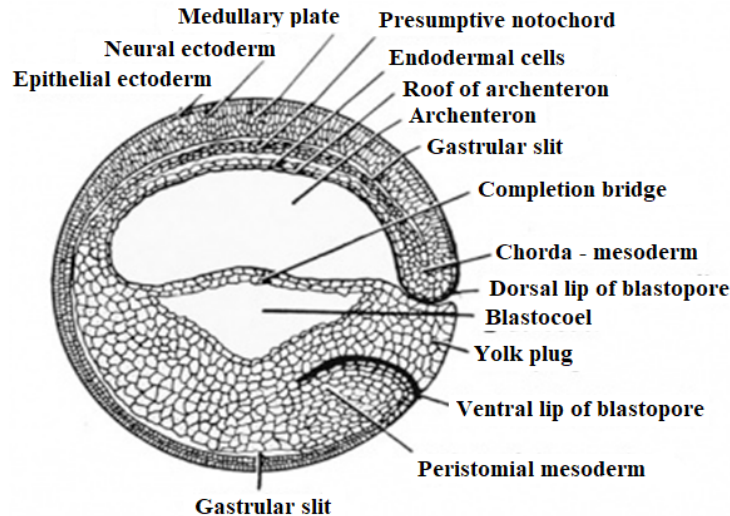

Fig. 4. Vertical Section of Yolk Plug Stage or Late Gastrula of Frog's Embryo

Experiment #2: To study the developmental stages of Chick Egg: 24 hours, 36 hours, 48 hours, 72 hours and 96 hours developmental stages.

Objective: To identify and describe the different developmental stages in chick's development from to 96 hours of incubation from permanent slides by observing under the microscope.

Introduction: As the egg of chick contains large amount of yolk which are concentrated at one end, the eggs are **megalecithal** and **telolecithal** eggs. Also since a hard outer shell covers the whole egg, it is **cleidoic egg**. All the embryonic development of chick occurs within this hard shell cover. During development, extra-embryonic membranes, i.e., yolk sac, amnion, chorion and allantois are formed within the egg. The yolk sac provides nutrition, amnion protects the embryo, chorion fused with allantois and along with allantois helps in excretion and respiration. These are also called temporary organ which serves until the time of hatching. Since the proper embryo developed within a fluid filled cavity, the amnions hence, they are **amniotes**.

The chick embryo developed from a small area of active protoplasm situated at the top of the yolk known as the **blastodisc** or **germinal disc**. The blastodisc contains the **zygote nucleus** which undergoes cleavage. It is whitish in colour and circular in outline. A darker area known as **periblast** or **marginal area** surround the white blastodisc.

Chick zygote undergoes **meroblastic discoidal cleavage** in which the cleavages furrows are restricted to the centre of the blastodisc surrounded by rim of unsegmented cytoplasm known as the periblast or marginal zone.

NOTES

NOTES

- At first, **all the cleavage planes are vertical** and all the blastomeres lie in one plane. The cleavage furrows separate the daughter blastomeres from each other but not from the yolk, so that the central blastomeres are continuous with the yolk at their lower ends.
- In the later stage of cleavage, **the blastomeres of the central area become separated from the underlying yolk** in one or two ways – slits appear beneath the nucleated parts of the cells or horizontal cleavage planes separate upper daughter cells from the lower blastomeres which still retains the connection with the yolk mass.

As the cleavage continues, the space between the upper blastomeres layer and the underlying yolk increase in size. This space is known as **subgerminal cavity** and the superficial layer is called the **epiblast**. Meanwhile, a small number of blastomeres remain underneath the epiblast, lying loose in the subgerminal cavity which subsequently unite forming a thin flat epithelium called the **hypoblast**. The space between the epiblast and the hypoblast form the **blastocoele** while the space between the hypoblast and yolk remain as subgerminal cavity. The type of blastula of chick embryo is known as **discoblastula**.

In chick's blastula, the cavity or blastocoele does not appear under the whole blastoderm but only under the central part of it. The blastodisc is thus subdivided into following two parts:

- a. **Area Pellucida:** This is the central part under which the cavity is formed.
- b. **Area Opaca:** This is the peripheral part which appear opaque because the blastomeres rest directly on the yolk.

The area pellucida form the body of the embryo while area opaca is concern with the breakdown of the underlying yolk.

During the early gastrulation stage, a narrow strip of blastoderm at the posterior edge of area pellucida thickened as the epiblast cells **converge** at the midline. This thickened strip of blastoderm is known as **primitive streak**. The primitive streak first becomes visible in the hindmost part of the area pellucida as **short primitive streak**. The primitive streak then elongates by concentration of more and more cells from the sides towards the midline in front of the original short primitive streak. The edges of the early primitive streak contracts and become narrow forming the **definitive primitive streak**. The movement in the blastoderm leading to the formation of the primitive streak is called **pregastrulation movements**, to distinguish them from gastrulation movement proper.

The formation of primitive streak is accompanied by **downward movement of many epiblast cells singly**. This type of gastrulation movement is called **immigration**. The immigrating cells reach hypoblast and establish an intimate contact with the cells of this layer. Henceforward the whole of

primitive streak is a solid mass of moving cells. The direction of the movement is mainly downward from the surface towards hypoblast and forward from the anterior end of the primitive streak.

In the later stage of gastrulation, due to mass movement of cells from the surface of the blastoderm into the interior, a narrow furrow – **the primitive groove**, appears along the middle of the fully developed primitive streak and the anterior thickening of the primitive streak, the **primitive knot** or **Hensen's node** is excavated to form a funnel shaped depression – the **Hensen's pit**.

As the cells of the epiblast continuous to migrate into the interior, the cells of the primitive streak keep on replacing by newly arrived cells from the adjoining areas. The first areas to start **invaginating** are the **presumptive prechordal plate**, the **notochord** and the **presumptive lateral mesoderm**. The presumptive notochordal cells become concentrated in the deeper parts of Hensen's node in the definitive primitive streak. After the prechordal plate has spread out in front of the anterior end of the primitive streak, the presumptive notochord cells start moving as a dense mass in the midline straight forward from Hensen's node underneath the surface of the epiblast. This mass of the notochordal cells is called the **head process** or the **notochordal process**.

The presumptive lateral mesoderm from the posterior part of the primitive streak starts migrating **downward, outward and forward**. The area of presumptive somites lies in the anterior part of the primitive streak which invaginates into the interior and later migrates outwards and forward and become distributed in a strip on each side of the notochordal process.

In the later stage of development, the influx of cells from the sides become retarded and can no longer compensate for the immigrating cells from the primitive streak. As a result, the primitive streak begins to shrink from the anterior end backwards.

As the primitive streak recedes backward, the neural system area which lies just in front of Hensen's node stretches backward along the midline and form the **presumptive neural plate**. The sheet of mesodermal cells along with the notochordal process is separated from the overlying epithelium, which no longer contains presumptive mesoderm or endoderm and forms the **ectoderm**. Similarly, the chorda-mesodermal layer also split off from the underlying hypoblast. This hypoblast which now consists of invaginating cells from surface through primitive streak is referred to as the endoderm. Hence in birds as well as in mammals, the original hypoblast only forms endoderm while epiblast forms ectoderm, mesoderm and endoderm.

As the Hensen's node recedes, the neural plate become more and more differentiated and the anterior part of the neural plate proceed to close into a tube, the **neural tube**. The notochord becomes separated from the adjoining sheets of mesoderm. The dorsal mesoderm becomes subdivided into segments – the **somites** while the lateral plate mesoderm split into following two layers:

NOTES

NOTES

1. The **External** or **Parietal** or **Somatic** Layer
2. The **Internal** or **Visceral** or **Splanchnic** Layer

The cavity between the two layers is termed as the **coelom**.

There is *no other cavity in the development of chick or birds* that could be considered as a homologue of the **archenteron**. However, the primitive streak through which the presumptive internal organs are invaginated into the interior of the embryo can be considered as the **blastopore** even if it does not lead into an archenteron. The *recession and disappearance of the primitive streak* therefore corresponds to the *closure of the blastopore*.

Since there is no archenteron, the presumptive alimentary canal of the embryo is represented by a narrow median part of the endodermal layer which forms a fold and later fused enclosing a cavity which will be the cavity of the alimentary canal. The closing of the alimentary canal take place only at its anterior and posterior ends. In the middle part, the folds continue to open towards the underlying yolk.

Material Required: Prepared permanent slides of Chick's Embryo at different hours of incubation, Compound microscope, Simple microscope.

CHICK EGG

1. The egg of chick is oval in shape with average length of 55 mm and width of 42 mm.
2. The egg of chick is surrounded by **egg's shell**. Hence the egg is classified as **Cleidoic egg**.
 - a. The eggshell is made almost entirely of calcium carbonate (CaCO_3) and is covered with as many as 17,000 tiny pores.
 - b. It protects the egg against physical damage and dehydration.
 - c. It is a semipermeable membrane, which allows air and moisture to pass through its pores.
3. The egg shell consists of three layers – two calcified layers, an inner **mammillary layer** and the outer **spongy** (or **crystalline**) **layer**; and the outermost thin shiny **cuticular membrane**.
4. The outermost **cuticular membrane** is made of glycoprotein and helps to keep out bacteria and dust.
 - a. The cuticle somewhat seals the pores and is useful in reducing moisture losses and in preventing bacterial penetration of the egg shell.
 - b. Most of the cuticle is removed from table eggs when they are mechanically washed.
5. Two membranes, the **outer shell membrane** and **inner shell membrane** are present just inside the shell surrounding the albumen (white).

- a. These two membranes provide an efficient defence against bacterial invasion and are made partly of keratin.
 - b. The outer membrane sticks to the egg shell while the inner membrane sticks to the albumen.
 - c. When an egg is first laid, it is warm. As it cools, the contents contract and the inner shell membrane separate from the outer shell membrane to form the **air cell**.
6. The egg albumen consists of three distinct regions of varying viscosities.
- a. A layer of thin albumin surrounding the yolk.
 - b. A layer of thick albumen surrounding the inner thin albumin.
 - c. Another layer of thin albumin external to the thick layer of albumen.
7. The albumen consist 88% water and the rest is primarily glycoproteins, the most abundant of which is **ovalbumin**. It is a major source of water for the developing embryo.
8. A very dense part of albumin is coiled into two cordlike structures which is attached very tightly to the yolk membrane. These are the **chalazae** (pronounced *ka-lay-zee*) and serve to keep the yolk centered.
9. The chalazae also allow the rotation of yolk and maintain specific orientation such that the animal pole always faces upwards.
10. The yolk is surrounded by a clear thin membrane, the **vitelline membrane**.
11. **Germinal Disk (Blastodisc)**: It is a small, circular, white spot (2-3 mm across) on the surface of the yolk; it is where the sperm enters the egg.
- a. The nucleus of the egg is in the blastodisc.
 - b. The embryo develops from this disk, and gradually sends blood vessels into the yolk to use it for nutrition as the embryo develops.
12. The yolk beneath the blastodisc can be differentiated into two distinct regions – a darker coloured yellow yolk and lighter white yolk.
13. **Yellow yolk** is due to carotenoid pigments and is major source of vitamins, minerals, almost half of the protein, and all of the fat and cholesterol.
- a. The yolk contains less water and more protein than the white, some fat, and most of the vitamins and minerals of the egg. These include iron, vitamin A, vitamin D, phosphorus, calcium, thiamine, and riboflavin.
 - b. The yolk is also a source of lecithin, an effective emulsifier.
14. **White yolk**, also known as, the **latebra** is an area of white yolk located in the center of the yolk.

NOTES

NOTES

- a. It contains lower fat and therefore stands out as a bright white area in many Magnetic Resonance Images (MRI).
 - b. The specific function of the latebra is uncertain but it may act as a central structure around which the additional layers of the yolk are formed.
15. As the egg contains large amount of yolk it is also called as **megalecithal** and since the yolk platelets are highly concentrated at one end, polarity is distinct and hence the egg is called as **Telolecithal egg**.

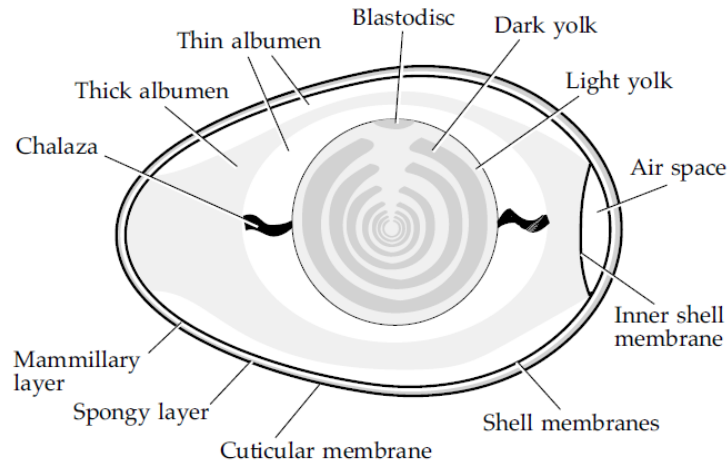

Fig. 5. Schematic Diagram of a Chick Egg. (Courtesy: Mary S. Tyler, 1994. Developmental Biology: A Guide for Experimental Study)

24 HOURS CHICK EMBRYO

1. At 24 hours of incubation, the neural folds and the neural plate is much more clearly marked.
2. The neural folds appear as a pair of dark bands forming neural groove.
3. The neural folds at the cephalic ends are more prominent than at caudal end.
4. The notochord is elongated and extends throughout the anterior two-third of the blastodisc along the midline. Its posterior end is broader than the cephalic ends.
5. The **proamnion** is present in the cephalic region.
6. Foregut is also established at this stage and the opening of the midgut into the foregut – **anterior intestinal portal** is also visible.
7. Mesoderm in front of the Hensen's node is segmented into **four pairs of somites** on either side of neural tube.
8. The Hensen's node is pushed caudally and the primitive streak is further reduced.

9. Primitive groove and the neural groove are separated by Hensen's node.
10. **Area Opaca** has greatly expanded.
11. **Area Vasculosa** formed as blood and blood-vessel developed in the inner portion of the area opaca. **Blood Island** is also visible as small aggregation of blood cells in the area vasculosa.
12. The outer portion of the area opaca which lacks blood vessels becomes **Area Opaca Vitellina**.

NOTES

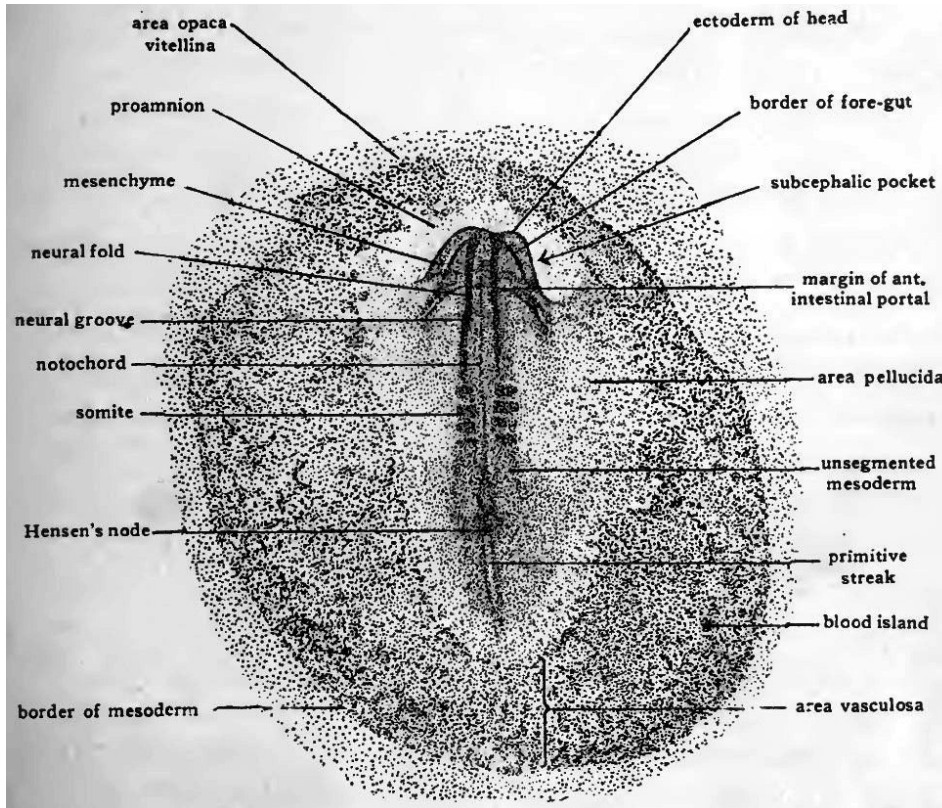

Fig. 6. Whole Mount of 24 Hours Chick Embryo (Courtesy: Patten BM. The Early Embryology of the Chick)

36 HOURS CHICK EMBRYO

1. After 36 hours of incubation, the central nervous system and circulatory system showed mark differentiation.
2. During this period of incubation there are also changes in the foregut region, somites, and differentiation in the intermediate mesoderm which leads to the formation of the urinary organs.
3. With the closure of the neural pore, the anterior end of the neural tube (primordial brain tube) is differentiated into three distinct regions – Prosencephalon (Forebrain), Mesencephalon (Midbrain) and Rhombencephalon (Hindbrain).

NOTES

4. The optic vesicles are established as paired lateral outgrowths of the prosencephalon which extend towards the superficial ectoderm.
5. A median ventral outgrowth known as **infundibulum** developed from the floor of the prosencephalon.
6. The formation of heart form cardiac vesicle is seen as a tubular structure in the mid-ventral region to the foregut.
7. Area opaca and area pellucida are not visible. However, area vasculosa increases in size with prominent extraembryonic blood vessels - anterior omphalomesentric vein and vitelline artery.
8. The primitive streak is highly reduced because of extension of neural canal and neural folds.
9. The notochord has extended from behind the brain up to the end of body.
10. The mesoderm, in front of Hensen's node, has given rise to 13-14 pairs of somites.

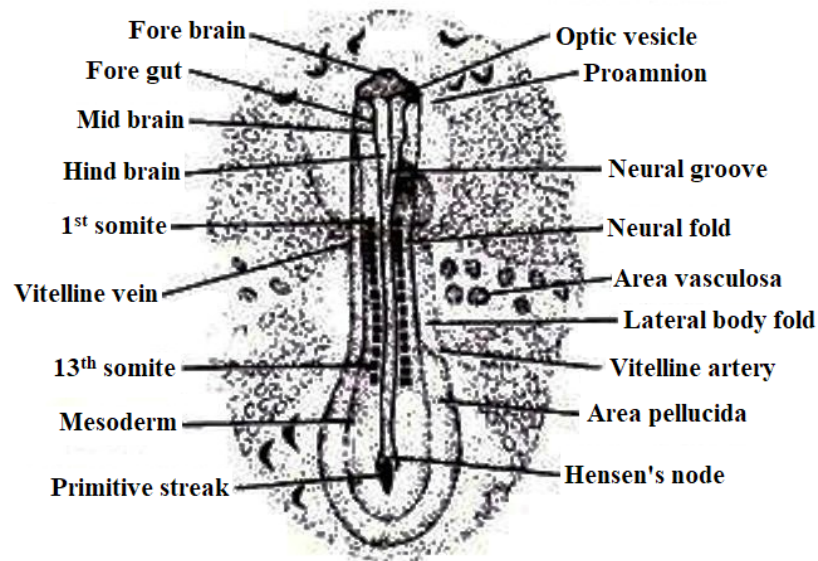

Fig. 7. Whole Mount of 36 Hours Chick Embryo

48 HOURS CHICK EMBRYO

1. After 48 hours of incubation, the chick embryo appears **dumb – bell shaped**.
2. The neural tube is closed along most of the length.
3. The opening of the neural tube – **the neuropore** is closed.
4. In addition to the head fold of the amnion, also the lateral and caudal amniotic folds begin to form.

5. Cranial flexure and torsion appeared.
6. In 48 hours chick embryo, two **flexures**, i.e., *bending of the body about a transverse axis*, are seen.
 - a. One is at the region of midbrain which sharply bends the forebrain to the ventral side. Because of this forebrain and hindbrain will become parallel. This is called **cranial flexure**.
 - b. In the posterior region of brain between the caudal portion of the myelencephalon and the anterior part of the spinal cord develops a **cervical flexure**. It bends the entire brain region of chick ventrally.
7. **Torsion**: The 24 hours chick embryo is flat. Its ventral surface is in contact with yolk. As the development proceeds the anterior end of embryo is turns towards left and hence the **anterior part of embryo comes to lie on the left side of yolk**. This twisting of the body is called **torsion**.
 - Torsion begins in the cephalic region of the embryo and progresses caudad.
8. Due to flexure and torsion, at the end of 48 hours, the chick embryo becomes **“C” – shaped**.
9. The brain divides into 5 vesicles:
 - a. **Telencephalon** and **Diencephalon** are both formed by the division of the forebrain vesicle – the prosencephalon.
 - b. **Mesencephalon**,
 - c. **Metencephalon** and **Myelencephalon** are both formed by the division of the hindbrain vesicle – the rhombencephalon.
10. The **optic vesicle** flattens at a point and will invaginate to produce the optic cup.
11. The ectoderm overlying the lateral wall of optic vesicle thickened to form **lens placode**.
12. The tubular heart is enlarged and flexed to **form “S” – shaped structure**.
13. The heart differentiates into 4 compartments as follows:
 - a. The **Sinus Venosus**, connected with the Veins.
 - b. The **Atrium**.
 - c. The **U-Shaped Ventricle**.
 - d. The **Bulbus Cordis**.
14. The vitelline arteries and veins become connected with the extra embryonic circulatory vessels and formation of extra-embryonic and intra-embryonic circulatory system is completed.
15. Formation of few branchial arches with branchial grooves is visible.

NOTES

NOTES

16. The mesoderm is segmented into **26 - 28 pairs of somites**.
17. Pronephros is completely developed. Mesonephric tubules start developing from the intermediate mesoderm.

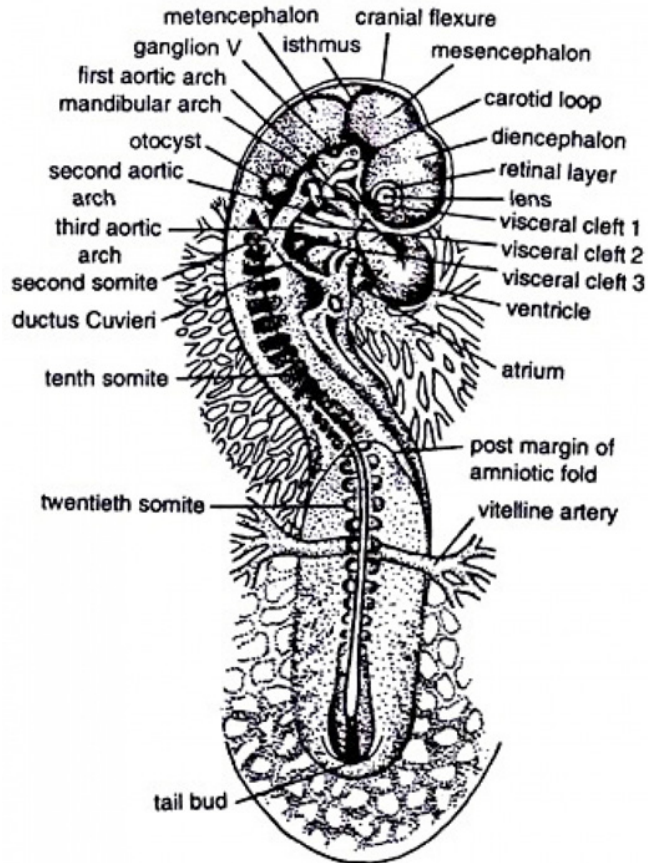

Fig. 8. Whole Mount of 48 Hours Chick Embryo

72 HOURS CHICK EMBRYO

1. The area vasculosa continues to spread over the surface of the yolk.
2. Area opaca vitelline and area pellucida are not visible.
3. Primitive streak has completely disappeared.
4. The **two flexures in the head region are almost completed** and the long axis of the embryo shows nearly right angled bends in the midbrain (cranial flexure) and neck region (cervical flexure).
5. The cervical flexure is so pronounced that the hindbrain forms the most anterior part of the embryo and forebrain comes to lie at the level of the heart.
6. Torsion is complete up to the posterior level of the heart and only the caudal portion of the embryo must twist 90°.

NOTES

7. The tail flexure has demarcated a definite caudal end of the trunk which now terminates in a conical **tail bud**.
8. Mid body becomes concave.
9. Pharynx and four pharyngeal pouches are formed. The **pharyngeal arches** are thicker.
10. A shallow olfactory pits lie near the tip of the head just beside the ventricle (heart).
11. Optic cup and lens and optic vesicle have been developed fully.
12. The hindgut terminates near the tail bud.
13. The diencephalon bears a small dorsal evagination – **the epiphysis**.
14. **35 – 36 pairs of somites** are present.
15. **Appendage rudiments** appears as a pair of small bud-like outgrowths from somites.
16. The anterior appendages arise opposite somites 17 to 19 inclusive, and the posterior appendages arise opposite somites 26 to 32 inclusive.
17. **Allantois** appears as a local bulge out of the hindgut and is concealed by the posterior appendage buds.

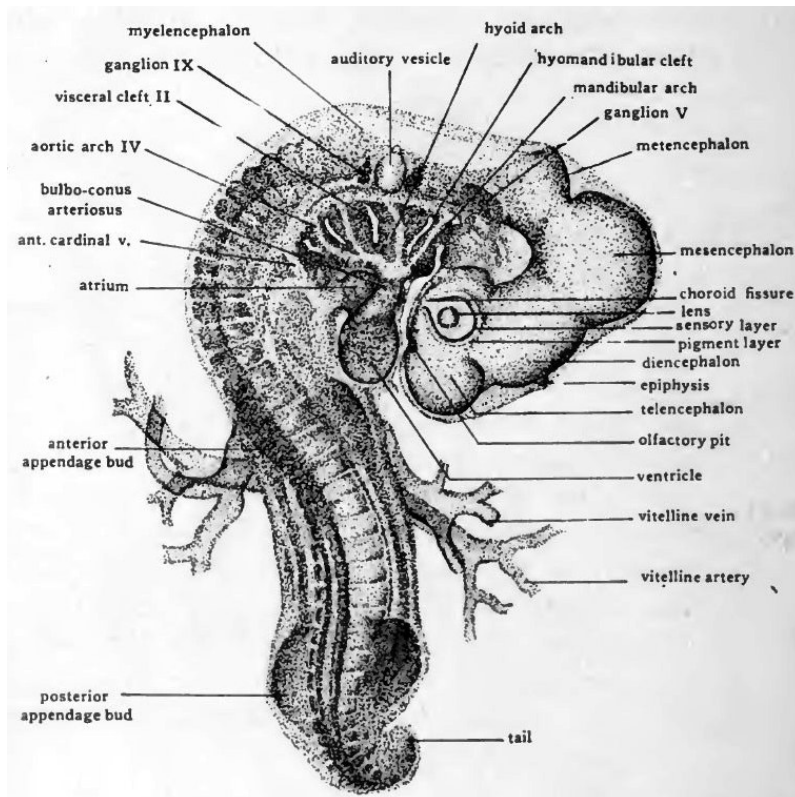

Fig. 9. Whole Mount of 72 Hours Chick Embryo (Courtesy: Patten BM. *The Early Embryology of the Chick*)

96 HOURS CHICK EMBRYO

NOTES

1. In the chick embryo of 96 hours of incubation, the entire body has been turned through 90 degree and the embryo lies with its left side on the yolk.
2. At the end of 96 hours the body folds have undercut the embryo so that it remains attached to the yolk only by a slender stalk.
3. The yolk stalk soon become elongated, allowing the embryo to become first straight in the mid-dorsal region and then convex dorsally.
4. The progressive increase in the cranial, cervical, dorsal and caudal flexures results in the bending of the embryo on itself so that its originally straight long axis becomes C-shaped and its head and tail lie close together.
5. During the fourth day the appendage buds increase rapidly in size and become elongated forming paddle like structure.
6. Allantois in four-day embryos has undergone rapid enlargement and projects from the umbilical region as a stalked vesicle of considerable size.
7. Optic cup shows the more developed lens.
8. Endo-lymphatic duct arises from the auditory vesicle.
9. Visceral arches have become very much thickened.
10. The number of somites increases up to 41 pairs.
11. Omphalomesenteric artery and Omphalomesenteric vein are also developed.

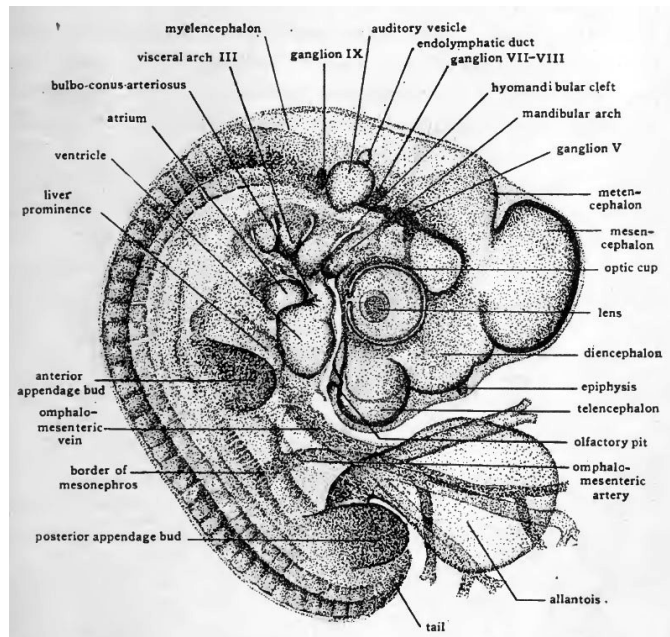

Fig. 10. Whole Mount of 96 Hours Chick Embryo (Courtesy: Patten BM. *The Early Embryology of the Chick*)

Experiment #3: To study different types of Placenta in Mammals.

Introduction: A placenta is a temporary organ in the uterus of pregnant mammals (except monotremes) that supply nutrients and facilitate excretion and gas exchange between the mother's blood and foetus's blood through umbilical cord. The umbilical cord consist of two arteries and a vein surrounded by Whorton's Jelly. All the viviparous mammals possess microlecithal eggs. Therefore, the amount of yolk present in them is not sufficient to fulfil the needs of developing embryo. In such case, embryo attaches itself to the uterine wall through the placenta in order to take the nutrition. The placenta is rich in blood vessels and is expelled with the fetal membranes during the birth process; together, these structures form the afterbirth.

Development: Placenta is formed by differentiation of trophoblast cells of blastocyst. During implantation, the trophoblast differentiates into two layers: the outer **Syncytiotrophoblast (ST)** with no cell boundaries (syncytium) formed by fusion of some trophectodermal cells and the inner **Cyotrophoblast (CT)** which lies between inner cell mass and syncytiotrophoblast, generate new trophoblastic cells. The syncytiotrophoblast produces lytic enzymes that cause apoptosis of the endometrial epithelial cells and helps in implantation. The cytotrophoblast cells forms villi containing blood vessels which invades the syncytiotrophoblast layer. These blood vessels later bath in the maternal blood pool in the intervillous space developed inside the syncytiotrophoblast layer. Exchange of gases and nutrient take place between the maternal blood in the intervillous space and foetal blood inside the foetal blood vessels.

Functions of Placenta

- It also acts as a physiological barrier between mother and the foetus thus also facilitate the foetal and maternal blood mixing.
- It helps in supplying the nutrition and oxygen to foetus.
- It helps in the diffusion of monosaccharide, amino acids, hormones, vitamins, oxygen, carbon dioxide, water along with other waste materials.
- It also acts as an excretory organ and releases their nitrogenous waste materials into the mother's blood.
- It can also function as an endocrine gland which secretes the lactogen, progesterone, etc.
- It also converts the glucose into fructose.

NOTES

NOTES

Types of Placenta

Placenta can be classified on the basis of following three different parameters:

- On the basis of **Membrane of Origin**, placenta is classified into two types – Chorio-Allantoic Placenta and Chorio-Vitelline (Yolk Sac) Placenta.
- On the basis of **Distribution Pattern of Villi**, placenta is of four types – Diffuse Placenta, Cotyledonary Placenta, Zonary Placenta and Discoid Placenta.
- On the basis of **Histology**, placenta is divided into five different types – Epithelio-Chorial Placenta, Syndesmo-Chorial Placenta, Endothelio-Chorial Placenta, Haemo-Chorial Placenta and Haemo-Endothelial Placenta.

Classification of Placenta Based on Membrane of Origin

Mammalian placenta is composed of the chorion, allantois or yolk sac, which form the extraembryonic membrane of the foetus along with the endometrium of the uterine wall (Decidua Basalis). Hence, the placenta is classified into two different types – Chorio-Allantoic Placenta and Chorio-Vitelline (Yolk Sac) Placenta.

CHORIO-ALLANTOIC PLACENTA

1. Such type of placenta is composed of chorion and allantois membrane of foetus.
2. Allantois is a sac-like outgrowth from the hindgut of embryo, which is lined internally by endoderm and externally by the mesoderm.
3. Allantois grows in size and spreads in the extra-embryonic cavity where its mesoderm fuses with that of chorion so as to form the composite membrane called chorio-allantoic.
4. The chorion grows into finger like vascular projection known as **Chorionic Villi**.
5. The allantois forms the foetal blood vessels and vascularised the chorionic villi.
6. The uterine wall forms the corresponding depressions, known as crypts, which are then penetrated by the fetal villi forming the chorio-allantoic placenta.
7. The chorio-allantoic placenta absorbs nutrition from the maternal blood and carries it to the foetus with the help of allantoic blood vessels.
8. Chorio-allantoic placenta is characteristic of all eutherian mammals.

NOTES

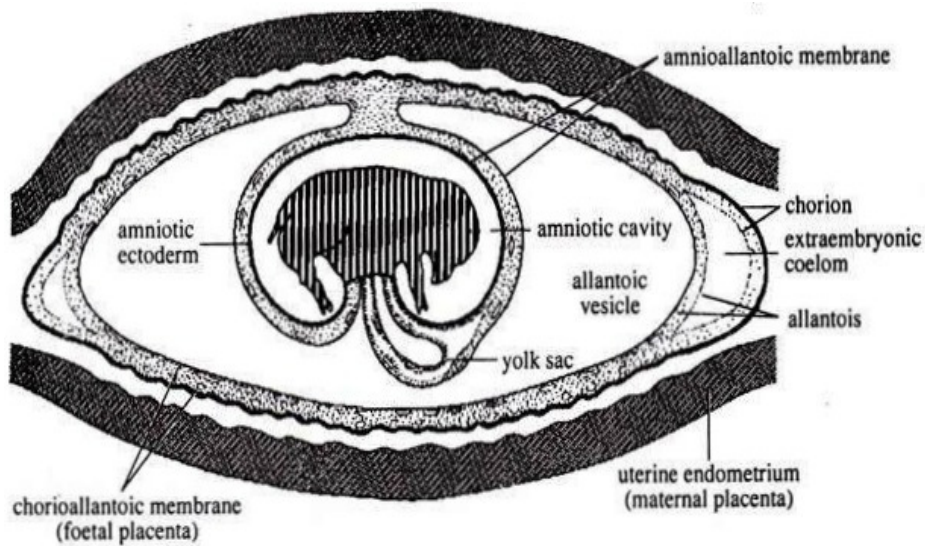

Fig. 11. Chorio-Allantoic Placenta

CHORIO-VITELLINE PLACENTA

1. Chorio-vitelline placenta are formed by chorion and yolk sac membrane of the developing embryo.
2. The yolk sac become enlarged and fused with the chorion to form the chorio-vitelline membrane.
3. The allantois remains relatively small and never contact with the chorion.
4. The chorionic membrane is vascularised by blood vessels derived from the yolk sac membrane.
5. In such placenta, the chorionic villi are absent and the chorion remains as smooth membrane applied closely to the endometrium of the uterus.
6. It is found in most marsupials.
7. In some eutherians mammals, including carnivores, rodents and insectivores, it is formed temporarily or permanently.
8. In those mammals in which the yolk sac placenta is formed temporarily, the yolk sac forms the initial vascular supply which gradually regresses. Meanwhile, the allantois develops and reaches the chorion which take up the task of vascularising chorion.

NOTES

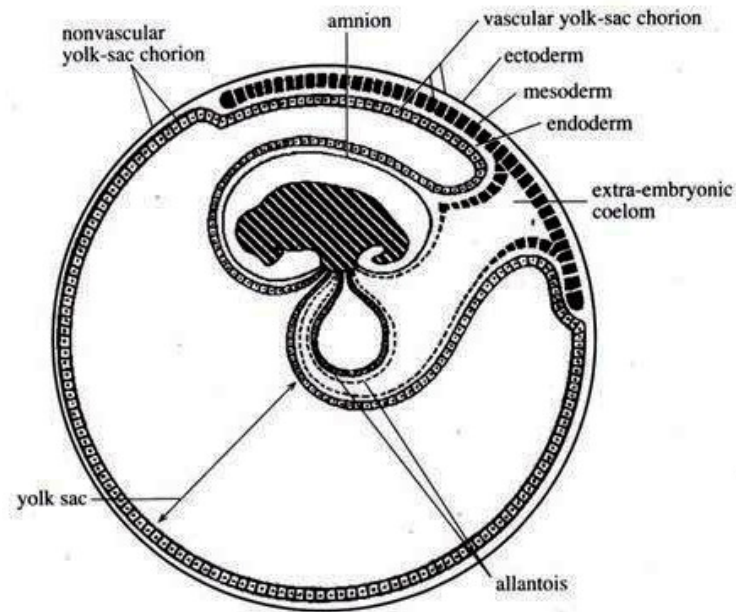

Fig. 12. Chorio-Vitelline Placenta

Classification of Placenta Based on Distribution Pattern of Villi

Based on the distribution pattern of chorionic villi over the surface of the placenta, there are four types of placenta – Diffuse Placenta, Cotyledonary Placenta, Zonary Placenta and Discoid Placenta.

DIFFUSE PLACENTA

1. In diffuse placenta, the chorionic villi are distributed evenly throughout the surface of the chorion.
2. The chorionic villi are small and numerous,
3. They extend into processes in the uterine endometrium.
4. The degree of contact between the foetal placenta and maternal placenta is least in this type of placenta.
5. It is found in Horses, Pigs, Camels, Lemurs, Opossums, Kangaroos, and Whales.

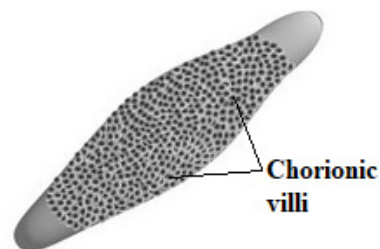

Fig. 13. Diffuse Placenta

COTYLEDONARY PLACENTA

1. In cotyledonary placenta, the chorionic villi are clumped together into multiple, discrete circular patches called **cotyledons**.
2. These cotyledons are formed by interaction of patches of allanto-chorion with endometrium.
3. Cotyledons form the foetal portions of the placenta while the maternal contact sites on the endometrium are called **caruncles**.
4. A cotyledon and its corresponding caruncle form a cotyledon – caruncle complex known as **placentome**.
5. Placentome is where the maternal-foetal exchanges take place.
6. These types of placenta are common to ungulates, such as Cows, Deer, Goat, and Giraffe.

NOTES

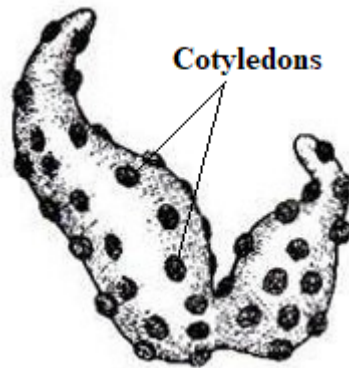

Fig. 14. Cotyledonary Placenta

ZONARY PLACENTA

1. In zonary placenta, the chorionic villi are aggregated to form a broad annular or girdle-like zone that circles about the center of the chorion.
2. This chorionic villi zone is where the maternal-foetal exchanges takes place.
3. The chorion is more or less elliptical in shape.
4. Such zones of chorionic villi may be complete circles or incomplete.
5. Complete zonary placentae are found in Dogs and Cats while incomplete zonary placentae are found in Bears and Seals.
6. Zonary placentae are characteristics of carnivores.
7. It is believed that zonary placentae are formed from diffuse placentae in which the villi at the ends regress, leaving only those in the center to function.

NOTES

8. A green **hemophagous organ** is present at the edges of the zonary placenta. The green color is due to the degradation of hemoglobin into biliverdin which provides iron for the developing foetus.

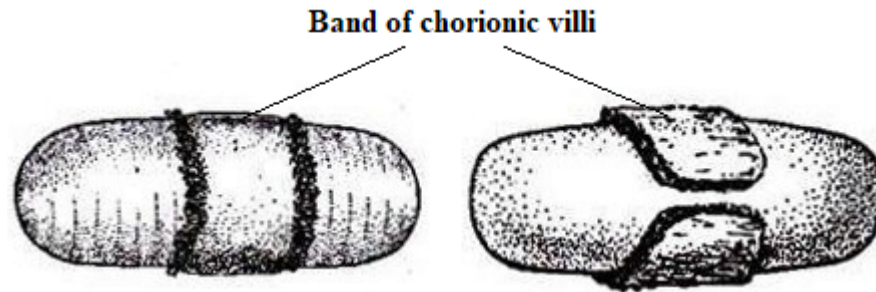

Fig. 15. Complete and Incomplete Zonary Placenta

DISCOID PLACENTA

1. In discoid placenta, the chorionic villi are aggregated in a circular disc or plate on dorsal surface of the chorion.
2. These types of placentae are found in many mammals including Humans, Mice, Insectivores, Rabbits, Rats and Monkeys.
3. In humans, only one disc of villi is present, hence it is known as mono-discoidal placenta.
4. Bi-discoidal placentas with two discs of villi are found in primates (Monkey).

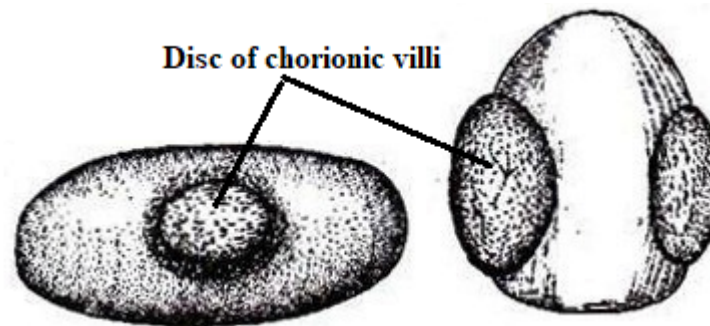

Fig. 16. Mono-Discoidal and Bi-Discoidal Placenta

Classification of Placenta Based on Histology

Histologically the maximum number of membrane or tissue barriers that can be present between the foetal and maternal blood streams is six. Out of these six layers, three layers originate from the foetal extraembryonic membrane of chorio-allantoic placenta while the other three layers are maternal tissues.

The three foetal layers are as follows:

1. Foetal endothelium lining allantoic capillaries.
2. Foetal connective tissue in the form of chorioallantoic mesoderm.
3. Chorionic epithelium, the outermost layer of fetal membranes derived from trophoblast.

The three maternal tissues are,

- a. Endothelium of Maternal Blood Vessel
- b. Endometrial Connective Tissue
- c. Uterine Epithelium

Although most of the placenta in mammals retains the three foetal layers, there is considerable variation in the degree of maternal tissues retained during the development of placenta. Accordingly, the placenta are classified into five different types based on their histology, i.e., tissue composition. These are,

1. Epithelio-Chorial Placenta
2. Syndesmo-Chorial Placenta
3. Endothelio-Chorial Placenta
4. Haemo-Chorial Placenta
5. Haemo-Endothelial Placenta

EPITHELIO-CHORIAL PLACENTA

1. In epithelio-chorial placenta, the maternal uterine epithelium is in closed contact with the foetal chorionic epithelium.
2. Therefore, all the six possible membrane barriers are present between the foetal blood and maternal blood streams. These are,
 - a. Foetal Endothelium
 - b. Foetal Connective Tissue
 - c. Foetal Chorionic Epithelium
 - d. Maternal Uterine Epithelium
 - e. Maternal Endometrial Connective Tissue
 - f. Endothelium of Maternal Blood Vessel
3. The chorio-allantoic villi lie in the pocket-like depression of the uterine wall.
4. It is the most primitive type of placenta from which all the other types of placenta are derived.
5. This type of placenta is found in ungulates (Horses, Pigs, Camels) Lemurs, and Marsupials (Opossums, Kangaroos).

NOTES

NOTES

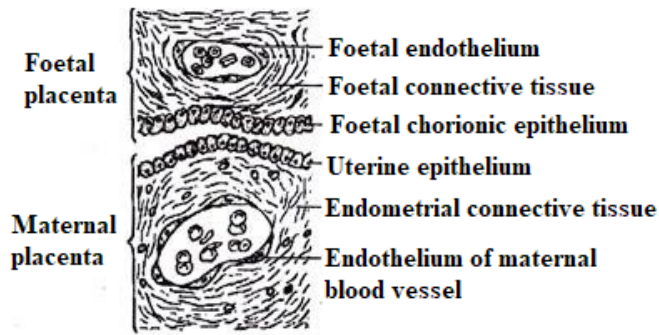

Fig. 17. Epithelio-Chorial Placenta

SYNDESMO-CHORIAL PLACENTA

1. In syndesmo-chorial placenta, the chorionic villi erodes the uterine epithelium. As a result, the uterine epithelium is ruptured.
2. Therefore, the foetal chorionic epithelium comes in contact with the endometrial connective tissue of the maternal placenta.
3. Only five layers are present between the foetal and maternal blood vessels, viz.,
 - a. Foetal Endothelium
 - b. Foetal Connective Tissue
 - c. Foetal Chorionic Epithelium
 - d. Maternal Endometrial Connective Tissue
 - e. Endothelium of Maternal Blood Vessel
4. These types of placenta are found in ruminant ungulates (Cattle, Sheep, Deer, Giraffe, etc.),

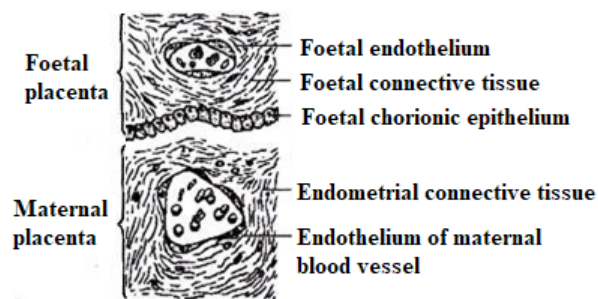

Fig. 18. Syndesmo-Chorial Placenta

ENDOTHELIO-CHORIAL PLACENTA

1. In endothelio-chorial placenta the chorionic villi erodes the uterine epithelium as well as the endometrial connective tissue.

NOTES

2. Therefore, the chorionic epithelium directly comes in contact with the endothelial wall of maternal blood vessels.
3. In this type of placenta, only four barriers remain between the maternal and foetal blood stream. They are,
 - a. Foetal Endothelium
 - b. Foetal Connective Tissue
 - c. Foetal Chorionic Epithelium
 - d. Endothelium of Maternal Blood Vessel
4. This type of placenta is characteristic of carnivores like Dog, Cat, Bear, etc.

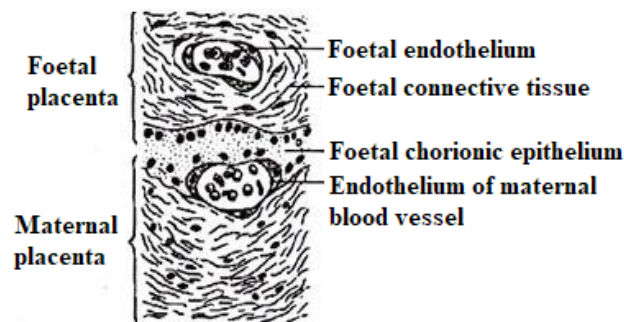

Fig. 19. Endothelio-Chorial Placenta

HAEMO-CHORIAL PLACENTA

1. Haemo-chorial placenta is characterized by reduction of barriers between maternal blood stream and foetal blood stream to only three layers.
2. All the maternal tissue barriers, viz., uterine epithelium, maternal endometrial connective tissue and endothelium of maternal blood vessel are eroded.
3. As a result, the foetal chorionic epithelium comes in direct contact with the maternal blood.
4. Only three barriers remains between the maternal blood and foetal blood stream, these are,
 - a. Foetal Endothelium
 - b. Foetal Connective Tissue
 - c. Foetal Chorionic Epithelium
5. The maternal blood circulates in the intervillus space inside the lacunae formed in thickened syncytiotrophoblast layer of the placenta.
6. This type of placenta is found in primates, insectivores (Mole, Shrew) and chiropterans (Bat).

NOTES

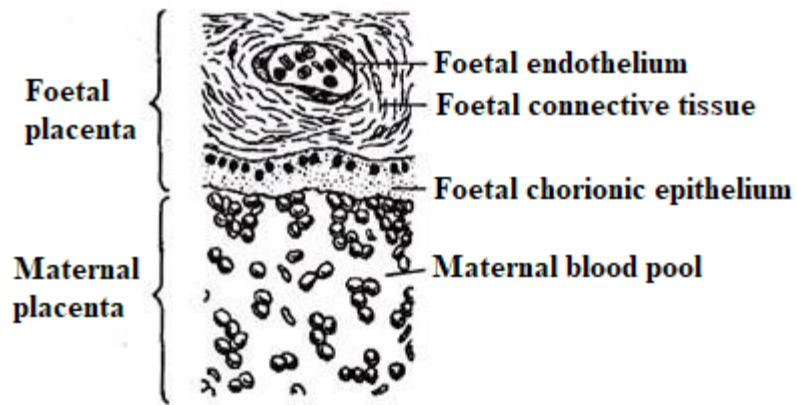

Fig. 20. Haemo-Chorial Placenta

HAEMO-ENDOTHELIAL PLACENTA

1. In haemo-endothelial placenta, the foetal placenta loses its chorionic epithelium and foetal connective tissue along with all the three maternal placenta tissue barriers, viz., uterine epithelium, endometrial connective tissue and maternal endothelial cells.
2. As a result, the foetal blood vessels directly come in contact with the maternal blood.
3. Therefore, the foetal endothelial cells remain the single barriers which separate maternal blood and foetal blood stream.
4. This type of placenta is found in Mouse, Rat, Rabbit, Guinea-Pig, etc.

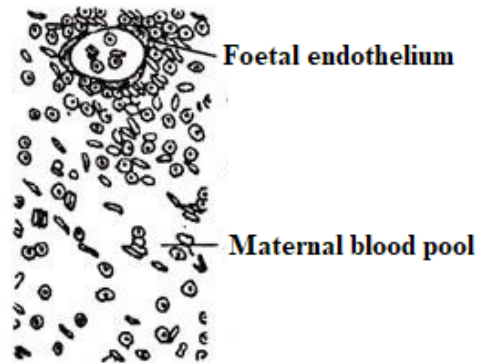

Fig. 21. Haemo-Endothelial Placenta

Experiment #4. Animals of Evolutionary Importance.

Objective: To study the evolutionary importance of various animals.

Introduction: Evolution encompasses the changes with time at the genetic level, organism level and population level. These changes help an organism to withstand the natural or manmade calamities and adapt themselves according to the present environment. Living fossils can act as the best way in order

to study the importance of evolution. A fossil is naturally preserved remains of animal or plants that existed in the geologic past while living fossil is a species which has no close living relatives and which are similar to species only found in fossils. Living fossils are not the same species as those species found in fossils; they only shared some common characters and common ancestors with the fossil species. Thus a living fossil is an animal that has survived beyond its era. It is the one species or such a group of species that has continued existence when the other closely related contemporary species have become extinct.

Apparatus and Materials Required: Preserved specimens of different animals, Compound microscope.

A. *Sphenodon punctatus*

Kingdom:	Animalia
Phylum:	Chordata
Class:	Reptilia
Order:	Rhynchocephalia
Family:	Sphenodontidae
Genus:	<i>Sphenodon</i>
Species:	<i>Punctatus</i>

Comments

This is an endangered species found on islands near the off coast of New Zealand. It is commonly known as 'Tuatara' by the native Maories. There are two species of *Sphenodon* - *Sphenodon punctatus* or the northern tuatara and *Sphenodon guntheri* or Brothers Island tuatara.

Geographic Distribution: This is an endangered species, once widely distributed throughout New Zealand, but became extinct on the mainland before the arrival of European settlers. Today, they are restricted to coastal islands.

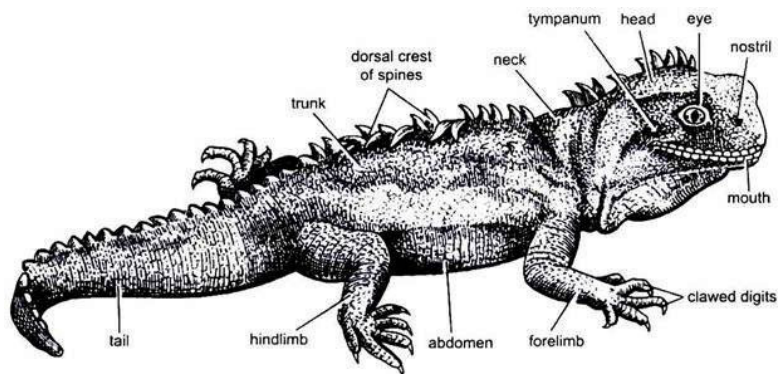

Fig. 22. *Sphenodon punctatus*

NOTES

NOTES

Habit and Habitat: they are solitary burrowing animals living in cold and damp area with temperatures between 60 to 70°F, and a humidity level of about 80%. They are most active at night, but occasionally bask at the entrance to their burrows if it is sunny.

Food Habit: The tuatara has a very slow metabolism. Due to its low metabolic rate, the tuatara eats much less frequently than other reptiles. Their diet consists of arthropods, earthworms, snails, bird eggs, small birds, frogs, and lizards. Young tuataras are also occasionally cannibalized.

Reproduction: It takes between 10 to 20 years for a tuatara to reach sexual maturity. The female, on average, lays 5 to 18 eggs only once every 4 years, the longest reproductive cycle of any reptile. Mating occurs from mid-summer to early autumn and the eggs are laid during the spring or early summer. It takes incubation period from 12 to 15 months, with the development of the embryo.

General Characteristics

1. The lizard like body is about 2 feet long and the tail measures about one-third of the whole length of the body.
2. The laterally compressed body and tail have a series of dorsal spines along the middle line.
3. Limbs are pentadactyle, legs are short and primitive in nature.
4. The upper surface of the body is covered with small granular scales and the lower surface is covered with transverse rows of large squarish scales.
5. The head is large and there is prominent ridge over the eye.
6. Teeth are pleurodont and homodont like reptiles but they are monophyodont. A single row of lower jaw teeth fits in between a double row teeth in the upper jaw.
7. Skulls are diapsid with immovable quadrate.
8. *Sphenodon* retains the large parietal foramen, in which, is the non-functional median pineal eye.
9. The anal opening is transverse.
10. There is no copulatory organ (penis) in the male.
11. The vertebrae are amphicoelous with fully ossified intercentra.
12. The ribs are single headed and have uncinatate processes.
13. Abdominal ribs are present.
14. A median bone, the Pro-Atlas is present between the atlas and the occipital region of the skull.
15. A urinary bladder is present.

Evolutionary Significance

The tuatara is the only survivor of the reptilian order Rhynchocephalia, which evolved in the early Mesozoic era, about 200 million years ago. It has remained unchanged for 200 million years persisting as a primitive 'Living Fossil' showing the condition of diapsids of late Permian.

Primitive Characters of *Sphenodon*

There are several primitive characters of *Sphenodon* which justify it to be called a living fossil. These are,

1. The skull bones are shaped and disposed in the manner of extinct group of reptiles.
2. Teeth are fused to the jaw bones.
3. Presence of pineal foramen.
4. There are several characters which resemble that of Dinosaurs and other extinct reptiles.
5. It resembles with the ancient Homaeosaurs in several features except the presence of uncinat process of the ribs in *Sphenodon*.

Affinities of *Sphenodon*

Sphenodon possesses several characters which are present in different groups of animals.

Affinities with Amphibians

Sphenodon has some similarities with Urodela in their circulatory systems. These are,

1. Aortic arches arise from a short common stalk which is comparable to Conus Arteriosus of the amphibians.
2. Presence of Ductus Arteriosus and Ductus Caroticus.

Affinities with Dinosaurs

Similarities

1. Both have complete diapsid condition of the skull, i.e., the skull has two vacuities (fossae).
2. Both have fixed quadrate bone.
3. Abdominal ribs are present in both *Sphenodon* and Dinosaurs.
4. Uncinate processes of the ribs are present in both.

Differences

1. In Dinosaurs, double headed ribs are present while *Sphenodon* has single headed ribs.

NOTES

NOTES

2. Dentition is thecodont in dinosaurs while it is pleurodont in *Sphenodon*.
3. Absence of clavicle and interclavicles and parietal foramen in dinosaurs.

Affinities with Chelonia

Similarities

1. Fixed quadrate bone.
2. Caudal ribs fused with the vertebrae.
3. Pecten are absent in the eye.
4. Urinary bladder present.

Difference

1. Teeth absent in the chelonians, only horny beaks present.
2. Parietal foramen is absent in chelonians.
3. Vomer is unpaired in chelonia.
4. Sternum is absent in chelonia.
5. Cloacal opening longitudinal in chelonia but transverse in *Sphenodon*.
6. Males have penis (copulatory organ) in chelonian.

Affinities with Crocodilia

Similarities

1. Diapsid condition of the skull.
2. Fixed quadrate.
3. Presence of Pro-Atlas.
4. Presence of abdominal ribs.
5. Fusion of caudal ribs with vertebrae.
6. Uncinate process of ribs.
7. Presence of chevron bones.

Differences

1. Thecodont dentition in crocodiles.
2. Single nostril in crocodile but double in *Sphenodon*.
3. Procoelous vertebrae in crocodile and amphicoelous in *Sphenodon*.
4. Clavides are absent in Crocodilia.
5. Pecten is present in the eyes of crocodiles.
6. Penis present in male crocodile.

Affinities with Lacertilia

Similarities

1. The body plan is similar.
2. Pro-Atlas present.
3. Amphicoelous vertebrae is found in certain Geckos (Lizards).
4. Ribs are single headed.
5. Chevron bone present in both.
6. Parietal organ common.
7. Cloacal glands present.

Differences

1. Quadrate fixed in *Sphenodon*.
2. Most lizards have procoelous vertebrae.
3. Erect ilium (a pelvic girdle bone) in *Sphenodon*.
4. Clavicles and interclavicles present in *Sphenodon*.
5. Absence of Conus Arteriosus in Lacertilia.
6. Presence of Pecten in Lacertilia.
7. Uncinate process absent in Lacertilia.
8. Copulatory organs present in Lacertilia.

Since, *Sphenodon* (Order – Rhynchocephalia) retains many primitive characters and resembles chelonians, crocodilia and dinosaurs in many features; it is convincing that they belong to class Reptilia. Also, *Sphenodon* has many similarities with the present day lacertilians. Hence, these blends of primitive and modern characteristics of *Sphenodon* clearly suggest that they are primitive animals adapted to the present age. In fact, they have survived well beyond their era, hence a living fossil.

B. *Ailurus fulgens*

Kingdom:	Animalia
Phylum:	Chordata
Class:	Mammalia
Order:	Carnivora
Family:	Ailuridae
Genus:	<i>Ailurus</i>
Species:	<i>Fulgen</i>

NOTES

NOTES

Comments

It is commonly known as the Red Panda. They are the only living member of the Ailuridae family. There are two recognized subspecies of red pandas within the Ailuridae family, as follows:

- Smaller subspecies *Ailurus fulgens fulgens* is native to Nepal, Tibet, Bhutan and the Indian states of Assam and Sikkim.
- Larger subspecies *Ailurus fulgens styani* (also known as *Ailurus fulgens refulgens*) is native to Northern Myanmar and South-Central China. They are deeper red in colour than the *fulgens* subspecies.

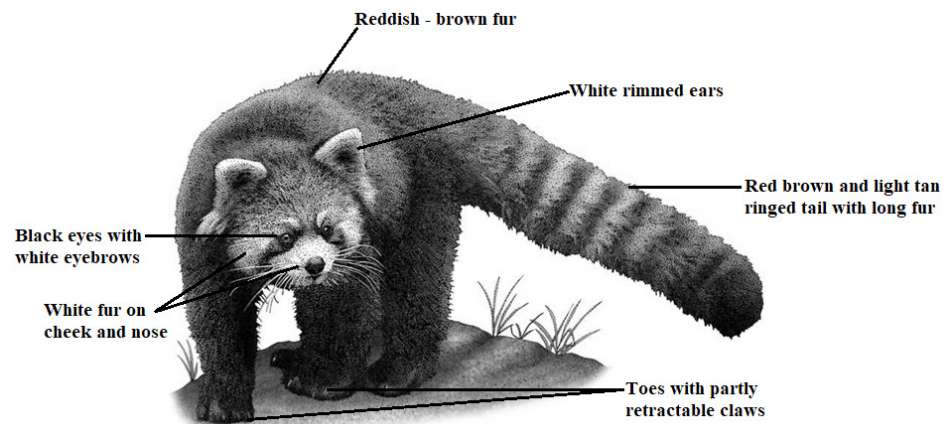

Fig. 23. *Ailurus fulgens*

Geographic Distribution: They are found in the Himalayas between 2,200 and 4,800 meters altitude in Northern Burma, Nepal, Sikkim region of India, and the districts of Western Sichuan and Yunnan in China.

Habit and Habitat: They live in temperate climates in deciduous and coniferous forests usually an understory of bamboo and hollow trees with average temperature is 10 to 25°C, and the average annual rainfall is 350 cm. Red panda gradually changes their activity throughout the year based on the temperature, feeding regimes, and the presence of young. They are most active at dusk, dawn, and during the night. They are arboreal, sleeping in nests in evergreens. They descend trees headfirst and display their flexibility as they move from branch to branch. The tail is used for balance when in trees, while on the ground it is carried straight and horizontally.

Food Habit: Red Pandas eat berries, blossoms, bird eggs, bamboo leaves, and the small leaves of other plants. They are specialized bamboo feeder with strong, curved and sharp semi-retractile claws standing inward for grasping narrow tree branches, leaves, and fruit. Bamboo leaves are the primary food source.

Reproduction: Mating season is early winter. Births occur in the spring and summer, with most new born arriving in June. All births take place between 4 pm and 9 am, which is the period of highest activity.

General Characteristics

1. Red Pandas are approximately 560 to 625 mm long, with relatively long, furry tails, from 370 to 472 mm long.
2. The tails are marked with about 12 alternating red and buff rings, and are not prehensile.
3. The head is round, the rostrum is shortened, and the ears are large, erect, and pointed.
4. Long, coarse guard hairs cover the body, and the undercoat is soft, dense, and woolly. The face is predominantly white with reddish-brown 'tear' marks under the eyes. The fur on the upper side of its body is reddish-brown, while ventrally it is glossy black. The legs are black and the soles of its feet are covered with dense, white hair.
5. The feet are plantigrade with the front legs angled inward, leading to its waddling walk.
6. Like Giant Panda, they possess pseudo-thumb which is a modified wrist bone used to grasp bamboo while feeding.
7. Their ankles are extremely flexible with tibia and fibula attached in such a way as to allow the fibula to rotate about its axis. These features make it possible for Red Pandas to adeptly climb headfirst down tree trunks.
8. The Red Panda has a robust skull with a poorly developed zygomatic arch, sagittal crest, and postorbital process.
9. The mandible is robust but relatively short, and the mandibular symphysis is constricted.
10. Premolar one and molar one and two are wider than their length and have accessory cusplets. Each upper premolar has more than one cusp, and premolar three has a well-developed paracone and hypocone.

Evolutionary Significance

1. Since, Red Panda are the only living member of the Ailuridae family, their taxonomic position has been under great debate. Until recently, no direct ancestors of the Red Panda were known. Most paleontologists link *Ailurus* with previous, Raccoon-like (Procyonoid) fossil animals, *Cynarctis*, *Phlaocyon*, *Aletocyon*, mainly by the similarities in their molars.
2. The closest fossil relative of *Ailurus* was found in Europe and North America in 1970's. It was about 50% larger than *Ailurus* and appropriately named as *Parailurus anglicus*.

NOTES

NOTES

3. According to Pen (1962), intermediate forms between *Parailurus* and *Ailurus* are not known. The smaller size diminished range of *Ailurus* suggests that it may represent a specialized offshoot of the early ailurine lineage and possibly even of an Asian form of *Parailurus* that survived the Pleistocene Glaciations in the Mountain Refugia of Southern China. Later in 2003, fossils of *Parailurus* were found in Japan which supports this view.
4. Recently in 2004, another fossil, *Pristinailurus bristoli* was discovered in Eastern Tennessee, USA which shows marked similarities with *Ailurus*. These two fossils, *Parailurus anglicus* and *Pristinailurus bristoli*, convinced the palaeontologists about the origin of *Ailurus* in Western Hemisphere.
5. Red Panda was earlier classified as a close relative of the Raccoon (Procyonidae) by French zoologist Frédéric Cuvier who first described it in 1825. This classification was based on physical similarities, such as the head, teeth and ringed tail. Also, both are great tree climber and small arboreal mammal.
6. Later because of its similarity with the parti-coloured Bear (Great Panda), Red Panda were assigned to the Bear Family (Family – Ursidae, Order – Carnivora). Parti – coloured Bear and Red Panda are very similar.
 - a. Their jaws and teeth were more like each other than they were like any other animal.
 - b. They lived near each other.
 - c. They both had false thumbs.
 - d. Their diets were similar which mainly consist of bamboo.
7. Like other carnivora, they also have a simple carnivore stomach, despite their predominantly leaf-based diet. However, in contrast with other carnivores of their size, Red Pandas have extremely robust dentition.
8. Most recent molecular phylogenetic studies show that Red Pandas are an ancient species in the Order Carnivora and are probably most closely related to the group that includes Weasels, Raccoons and Skunks. Therefore, they are placed in their own, independent Family Ailuridae.

C. Crocrodilia

Kingdom:	Animalia
Phylum:	Chordata
Class:	Reptilia
Clade:	Eusuchia
Order:	Crocrodilia

Comments

The order Crocodylia includes 23 species found in 100 tropical and subtropical countries all within 4000 km of the equator. They are divided into following three families:

- Crocodylidae** – The True Crocodiles which consist of 13 species.
- Alligatoridae** – They consist of 2 species of Alligators and 6 species of Caimans.
- Gavialidae** – They consist of 2 species of Gharial and the False Gharial.

NOTES

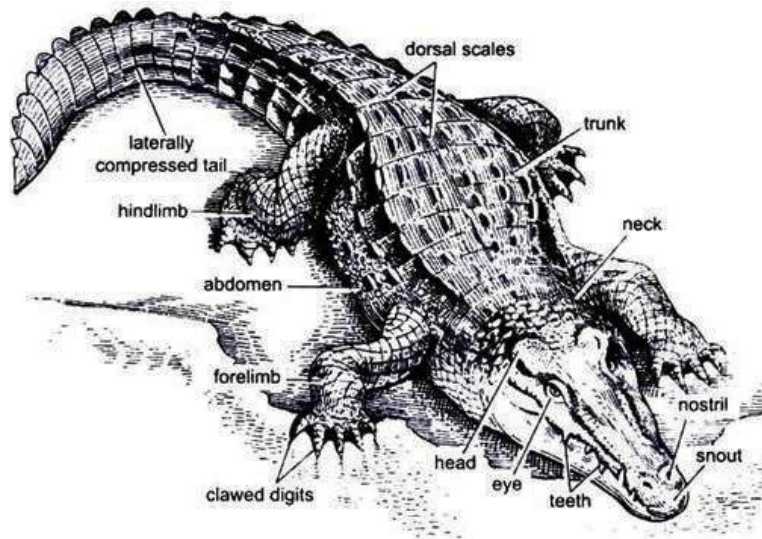

Fig. 24. *Crocodylus porosus* (Indian Freshwater Crocodile)

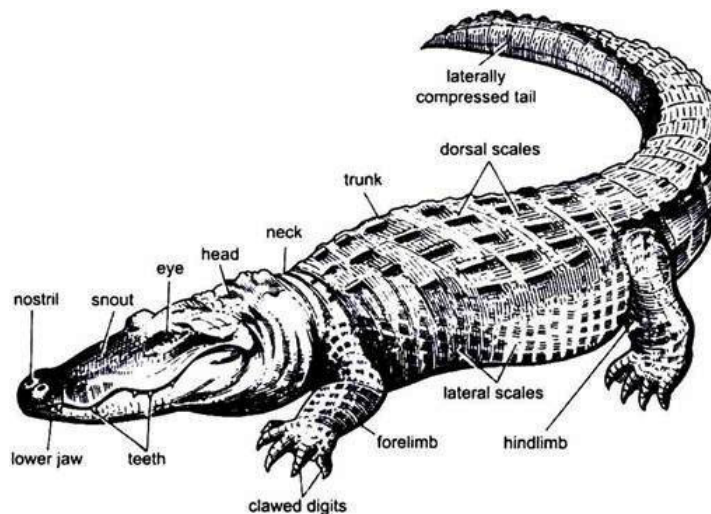

Fig. 25. *Alligator mississippiensis* (American Alligator)

NOTES

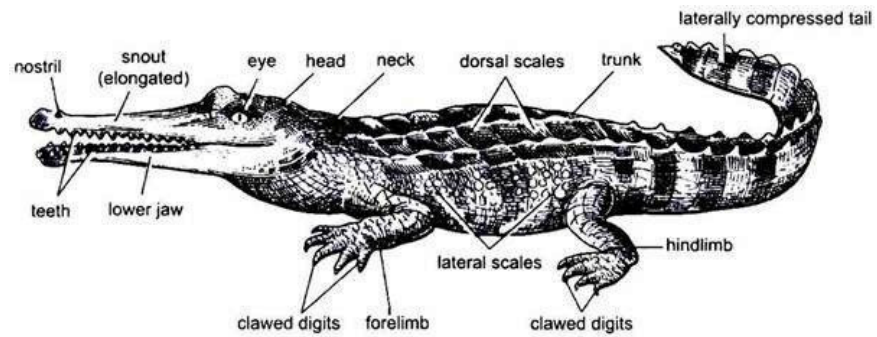

Fig. 26. *Gavialis gangeticus* (Gharial)

Geographical Range: Crocodiles are essentially Old World creatures found in Africa, Asia, and Australia while Alligators and Caimans are found in New World, i.e., America. On the other hand, Gharials are native of India and Nepal while False Gharial is found in South-East Asia in Borneo, Java, Vietnam, Thailand and Indonesia.

Habit and Habitat: They are poikilothermic in nature and are adapted to semi-aquatic life. None ever lives more than 1000 m from the sea level. They are normally solitary animals, but may bring together due to plentiful food. They communicate with each other by means of sign (sounds, postures, motions) or either releases some type of pheromones by four scent glands, and by touch. Adults are generally territorial, and mark their territory by loudly slapping their head down on the water or snapping their jaws on the surface of the water.

Reproduction: They lay their eggs in nests made out of plant material and/or mud. A single female typically lays a clutch of between 30 and 60 eggs that incubate for 80 and 90 days. Crocodilians are unusual among reptiles in the amount of parental care provided after the young hatch. The mother helps excavate hatchlings from the nest and carries them to water in her mouth. Newly hatched crocodilians gather together and stay close to their mother.

Food Habit: They are carnivorous and swallow their prey as whole. Generally, their staple food is fish but they may eat insects, tadpoles, frogs, snails, crabs, shrimps, birds, snakes, molluscs, turtles and bats. They are also opportunistic hunters of mammals.

General Characteristics

1. Crocodiles range in size from the African dwarf crocodile which grows to over 6 feet to the saltwater crocodile, which can grows to over 20 feet in length.
2. Crocodiles have large, broad bodies with short legs and long, muscular tails.
3. They have thick, leathery skin with bony, plate-shaped scales.

4. Teeth are pointed, cone shaped and like mammals are thecodont, i.e., grow inside a bony socket. However, unlike mammals, crocodilians can replace their teeth throughout their lives, i.e., they are polyphyodont.
5. Heads are long and pointed with the eyes and nostrils located on the top of the head. The three families of Crocodylia can be easily distinguished from one another on the basis of their shape of head.
 - a. Crocodylidae have relatively narrow snouts, lower teeth that are visible when their mouths are closed and they have a special notch on either side of their upper jaw for the fourth tooth of the lower jaw.
 - b. Alligatoridae have a wider, more rounded snout, their lower teeth are not visible and rest inside their upper teeth and mouth, and they lack the notch.
 - c. Gavialidae can easily be recognized because of their long, very slender snouts.

NOTES

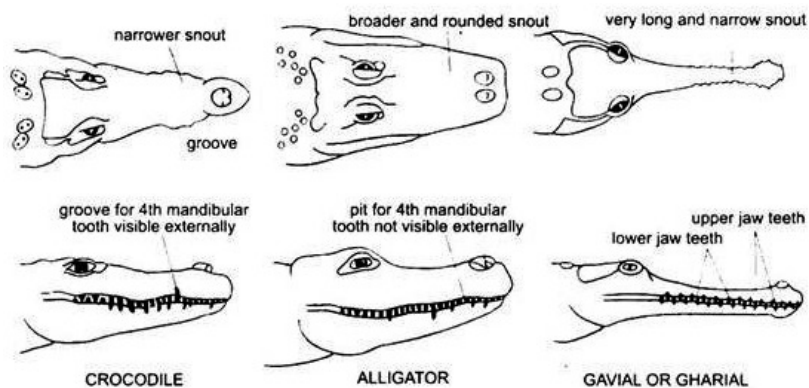

Fig. 27. Anatomy of Heads of Different Families of Crocodylia – Crocodile, Alligator and Gharial

6. Their skin is covered with non-overlapping scales composed of the protein keratin and often studded with bony plates called scutes.
7. They have spines that were more flexible up-and-down than from side-to-side; increasing stiffness of the trunk to cope with moving through the water at speed.
8. Their thoracic and abdominal cavities are separated by a muscular diaphragm, used in breathing.
9. They have 4 chambered heart.
10. The crocodylian stomach is divided into two chambers, a powerful and muscular chamber like gizzard of birds which have ‘Gastroliths’, which mean ‘Stomach Stones’, and other acidic chamber like mammals which can digest mostly everything, including their prey, bones, feathers, and horns.

NOTES

11. Crocodilians have a bony secondary palate which enables them to breathe when partially submerged, even if their mouth is full of water.
12. They never stop growing, the older the animal is the larger it is. Some species live for up to 75 years.

Evolutionary Significance

Crocodiles have been around for 240 million years, appearing 25 million years before the first dinosaurs and 100 million years before the first birds and mammals. *Sarcosuchus*, a crocodiles that lived 112 million years ago were up to 40 feet long.

The modern day crocodilians are believed to have appeared first in the Cretaceous Period about 95 million years ago. They are the closest living relative of birds, as the two groups are the only known survivors of the Archosauria which includes all Extinct Dinosaurs, Extinct Crocodilian Relatives, and Pterosaurs.

Crocodiles are regarded as the closest living relatives of dinosaurs. They have many dinosaur-like features including the following:

- Diapsid skull with an extra pair of openings in the skull, the antorbital fenestra in front of the eye sockets.
- Bird-like arrangements of the hip bones.
- Thecodont teeth, teeth that are mounted in sockets rather than being fused directly to the jawbone.

Crocodiles are also more closely related to birds than they are to snakes, geckos and other reptiles. For examples, birds and crocodiles have,

- Sophisticated four chambered hearts, while lizards and snakes have only three chambered hearts.
- Both have secondary bony plates.
- Crocodiles have a muscular chamber stomach which contains gastroliths and are analogous to gizzard of birds.
- Crocodiles also display a number of bird-like behaviours, such as building good nests, and brooding, protecting and fussing over their eggs.

D. Coelacanth

Kingdom:	Animalia
Phylum:	Chordata
Subclass:	Actinistia
Order:	Coelacanthiformes
Sub-Order:	Latimerioidei
Genus:	<i>Latimeria</i>

Comments

It belongs to a group of lobed-finned fish related to lungfish and certain extinct Devonian fish, such as osteolepiforms, porolepiforms, rhizodonts, and panderichthys. There are only following two existing species in the genus *Latimeria*:

- a. *Latimeria chalumnae* – The West Indian Ocean Coelacanth
- b. *Latimeria menadoensis* – The Indonesian Coelacanth

Geographical Range: The *Latimeria chalumnae* constitute the largest known population of Coelacanths which lives along the coasts of the Comoro Islands off the coast of Africa. *Latimeria menadoensis* is found in deep water of Sulawesi Island in Indonesia and Biak Island in Papua.

Habit and Habitat: They live in their caves roughly 100 to 200 metres below the water surface where temperatures range from 16° to 22°C. In the daytime, they generally aggregate in their caves and at night, they drift hunt individually.

Reproduction: They are ovoviviparous in nature. Fertilization is internal with females bearing their offspring internally for 13 months to 3 years. It has been observed that since males lack copulatory organ, they possess a modified cloaca to deliver gametes inside the female body.

Food Habit: They are opportunistic in their feeding habit. They frequently feed on *Coranthus polyacanthus*, *Beryx splendens*, *Lucigadus ori*, and *Brotula multibarbata*.

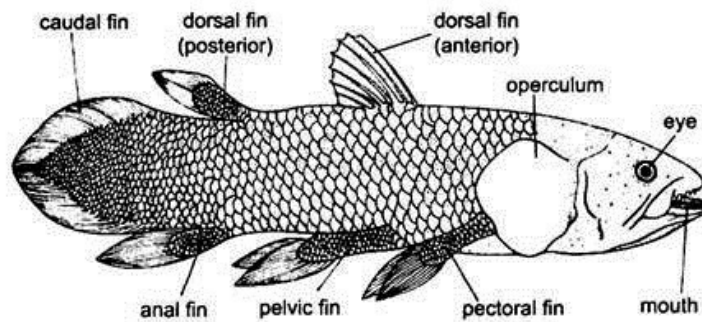

Fig. 28. *Latimeria chalumnae*

General Characteristics

1. Coelacanths can grow up to 2 m in length.
2. Their bodies are covered in blue scales, which turn brown after death, with a white speckling that is unique to each individual.
3. Coelacanths have eight fleshy lobed fins – 2 dorsal fins, 2 pectoral fins, 2 pelvic fins, 1 anal fin and 1 caudal fin. They move their two paired

NOTES

NOTES

sets of fins (pectoral and pelvic) in a diagonally synchronous manner like a four-limbed terrestrial animal.

4. Coelacanths possess an intracranial joint and an associated basicranial muscle for suction feeding or increases bite force.
5. Notochord is a hollow tube filled with fluid.
6. They also possess colour vision that is strongly adapted to a deep water environment.
7. They have a fatty organ that serves as a swim bladder. Within this fatty organ, a vestigial lung can be found that is surrounded by small hard plates involved in lung volume regulation in an ancestral species, but have become rudimentary in extant coelacanths.
8. The heart is primitive, S-shaped with the atrium and sinus venosus behind the ventricle. The conus arteriosus has four rows of valves.
9. Females are larger in size, and have higher thickness ratios and metabolic rates than males.
10. Average mass of adult females is 82.1 kg, and average length is 170 cm, for males average mass is 37.2 kg and length 125 cm.

Evolutionary Significance

This is an example of genetic diversity and adaptation in the living fossils. The fundamental morphology of Coelacanths has not changed in over 400 million years yet they are still able to genetically adapt to their environment. They thrived during the Devonian Age and are the closest relative of the last common ancestor of fish and land vertebrates still in existence today. They follow the oldest-known living lineage of *Sarcopterygii* (lobe-finned fish and tetrapods), which means they are more closely related to lungfish and tetrapods than to ray-finned fishes.

Primitive Character

They are referred to as a living fossil because it is believed that their morphology remains static over hundreds of millions of years. They share similarity in many characteristics with other Osteichthyes (bony skeleton and diphyccercal tail), Chondrichthyes (fat for buoyancy and ovoviviparity) while also have some specializations like a vestigial lung and intracranial joint.

Externally, several characteristics distinguish the Coelacanth from other lobe-finned fish.

- They possess a three-lobed caudal fin, also called a trilobate fin or a diphyccercal tail. A secondary tail extending past the primary tail separates the upper and lower halves of the Coelacanth.

- They possess cosmoid scales which are found in several ancient lobe-finned fishes, including some of the earliest lungfishes, and were probably derived from a fusion of placoid scales.

The vestigial lung inside the fatty organs was believed to be functional in ancestral species, but have become rudimentary in existing Coelacanth. These evidences show that they are not only related to ancestor of all bony fish, but are also related to the ancestor of the earliest amphibians and other vertebrates that later colonised the land.

NOTES

E. Platypus

Kingdom:	Animalia
Phylum:	Chordata
Class:	Mammalia
Order:	Monotremata
Family:	Ornithorhynchidae
Genus:	<i>Ornithorhynchus</i>
Species:	<i>Anatinus</i>

Comments

The Platypus (*Ornithorhynchus anatinus*), sometimes referred to as the Duck-Billed Platypus, is a semi-aquatic egg-laying mammal. They are the only mammals that lay eggs instead of giving birth to live young ones.

Geographical Distribution: They are generally found in the wetter regions of Eastern Australia and Tasmania.

Habit and Habitat: Duck-Billed Platypuses are solitary, especially males. They inhabit rivers, lagoons, and streams usually less than 5 meters in depth. They prefer areas with steep banks that contain roots, overhanging vegetation, reeds, and logs. Their home range size ranges from 0.37-7.0 km.

Reproduction: Mating is seasonal and varies with population. Duck-Billed Platypuses are one of the three mammal species that lay eggs. Female build burrows in which they protect and nurse their young ones. Their estimated gestation periods are 27 days and incubation periods are 10 days. During the incubation period, the female Platypus will incubate eggs by pressing the egg to her belly with her tail. The incubation period usually lasts for 6 to 10 days. They generally lay two to three eggs. Lactation lasts three to four months. Most juvenile females do not begin to breed until they are four years old.

Food Habit: They primarily feed on aquatic invertebrates in streams and lakes. They also eat shrimp, fish eggs, and small fish.

NOTES

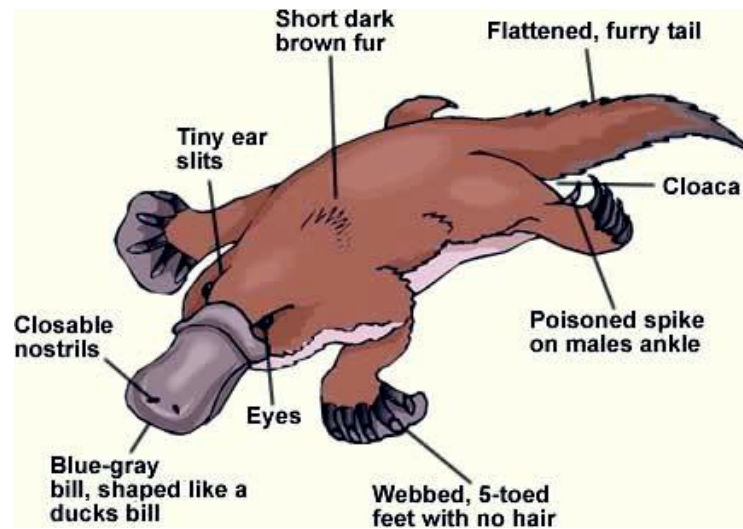

Fig. 29. *Platypus (Ornithorhynchus anatinus)*

General Characteristics

1. They have a cloaca through which eggs are laid and both liquid and solid waste is eliminated.
2. They are stream-lined and elongated body covered with fur ranging from medium brown to dark brown on the dorsal side and brown to silver-gray on the ventral side.
3. They have bills that closely resemble those of ducks, and flat and broad tails resembling those of beavers.
4. Two nostrils are located on top of their bills and their eyes, and ears are on either side of their heads.
5. They have short limbs, naked soles, webbed forefeet and partially-webbed hind feet.
6. Each foot contains five digits each consisting of a broad nail for the forefeet and sharp claws for the hind feet.
7. Males are generally larger than females, and have two venom glands attached to spurs on their hind legs. Females have mammary glands but no nipples.
8. The young have milk teeth while the adults have grinding plates.
9. The young are smaller than adults in size.
10. There is a significant reduction in body fat after winter for both young and adults.

Evolutionary Significance

It is one of the five existing species of monotremes. The animal is the sole living representative of its family – Ornithorhynchidae. Aquatically adapted

Platypus probably evolved from a more-generalized terrestrial monotreme about 110 million years ago, in the early Cretaceous Period. They includes the extinct genera *Monotrematum* (Paleocene Epoch, 61 million years ago) and *Obdurodon* (Oligocene and Miocene Epochs, 23 million years ago). Species of *Monotrematum* and *Obdurodon* retained functional teeth and were more robust than the living Platypus, Obdurodon measuring up to 60 cm (24 inches) long.

NOTES

Primitive Character

1. Opalised lower jawbone with three molar teeth.
2. The molar teeth were initially thought to be tribosphenic.
3. The platypus genome also has both reptilian and mammalian genes associated with egg fertilisation.

Platypuses have similarities with both mammals and reptiles.

Similarity with Mammals

1. Presence of mammary glands.
2. Presence of hair on entire body.
3. Presence of muscular diaphragm and single aortic arch.

Similarity with Reptiles

1. Having a large coracoid in pectoral girdle.
2. Laying eggs with yolk and shell.

F. Horseshoe Crab

Kingdom:	Animalia
Phylum:	Arthropoda
Subphylum:	Chelicerata
Order:	Xiphosura
Suborder:	Xiphosurida
Family:	Limulidae
Genus:	<i>Limulus</i>
Species:	<i>Polyphemus</i>

Comments

Horseshoe Crabs are marine and brackish (saline) water arthropods. The name is a misnomer because they are not true crabs being more closely related to Arachnids (Spiders and Scorpions) than to Crustaceans (True Crabs, Lobsters, and Shrimps).

NOTES

Geographic Distribution: They are found along the Atlantic Coast, from Nova Scotia to the Yucatan.

Habit and Habitat: The Horseshoe Crab can generally be found in shallow water, over sandy or muddy bottoms. They walk along the bottom of shallow water, but it can also swim awkwardly on its back by using its flap-like gills as paddles.

Reproduction: The first pair of the six, flap-like appendages on the underside of the abdomen acts as a cover for the genital pore. The egg or sperm are released through this pore during spawning. The female digs a hole in the sand and lays her eggs while the male(s) fertilize them. The female can lay between 60,000 and 120,000 eggs in batches of a few thousand at a time. It takes about two weeks to hatch. The larvae moult or sheds six times during the first year.

Food Habit: The Horseshoe Crab feeds at night on worms, small molluscs, and algae. Food is picked up by the chelicerae and passed back to the bristle bases, where it is 'chewed' and forward to the mouth.

General Characteristics

1. The entire body is covered with hard carapace.
2. The Horseshoe Crab has a unique and primitive body structure. It is composed of three parts: the Prosoma (head), Opisthosoma (central area) and Telson (tail).
3. Horseshoe Crabs have several pairs of eyes.
4. It has two compound lateral eyes (each composed of about 1,000 Ommatidia) on the Prosoma which is sensitive to polarized light and can magnify sunlight 10 times.
5. A pair of simple eyes on the forward side of the Prosoma to detect both visible light and ultraviolet light.
6. It also has a pair of rudimentary lateral eyes on the top which become functional just before the embryo hatches and a single endoparietal eye.
7. It has a pair of ventral eyes is located near the mouth, as well as a cluster of photoreceptors on the telson.
8. The Horseshoe Crab has five additional eyes on top of its shell. Despite having relatively poor eyesight, they have the largest rods and cones of any known animal, about 100 times the size of humans and their eyes are a million times more sensitive to light at night than during the day.
9. The mouth is located in the center of the legs, whose bases are referred to as gnathobases and have the same function as jaws which help in grinding the food.

NOTES

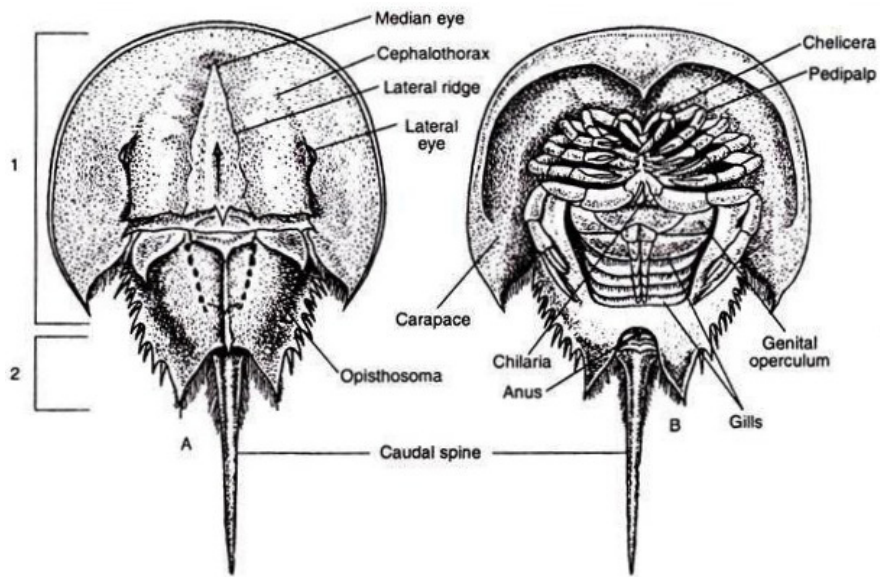

Fig. 30. *Limulus polyphemus*

10. The Horseshoe Crab does not have a conventional jaw while they have five pairs of legs for walking, swimming, and transferring food into the mouth, each with a claw at the tip, except for the last pair.
11. Book gills are present which exchange respiratory gases, and are also occasionally used for swimming.
12. A true endoskeleton is absent, but the body does have an endoskeletal structure made up of cartilaginous plates that support the book gills.

Evolutionary Importance: Their existence can be traced back through the geologic record to around 445 million years ago, 200 million years before dinosaurs existed. All these time, they remained unchanged, hence, are true living fossils.

Affinities of Horseshoe Crab

Horseshoe Crab has affinities with various groups of animals which can be roughly discussed under the following two broad headings:

- I. Affinities with Fossil Forms
- II. Affinities with Living Forms

Affinities with Fossil Forms

Similarities with Hemiaspidae (Fossil Crustaceans)

1. Large head is covered with dorsal shield.
2. A telson is present.
3. Two compound eyes are placed laterally.

NOTES

4. Larval form of Horseshoe Crab after first moult or shed resembles the members of the family Hemiaspidae.

Similarities with Trilobites

1. Cephalothorax with lateral eyes is present.
2. Appendages are biramous.
3. The body is longitudinally divided into three parts by two furrows.
4. Presence of lateral pleural spine.
5. Trilobite stage in the development of Limulus is highly suggestive of a relationship between the two groups, so far the structural peculiarities are concerned.

But at the same time, there are certain dissimilarities with Trilobites, as discussed below.

1. Trilobites have distinct dorsal segmentation and trilobation of the body which are absent in Limulus.
2. Absence of antennae in Limulus.
3. Structure of abdominal appendages and genital operculum also differs.

With Extinct Eurypterida

Similarities

1. The body in both has three regions— Prosoma, Mesosoma and Metasoma.
2. In both, the cephalothoracic appendages correspond in number and position.
3. Appearance of limb, presence of telson, presence of median and lateral eyes is the similar features in both.

Dissimilarities

1. Nature of abdomen in Eurypterida is different and shows resemblance with that of scorpion.
2. Nature of cephalothorax is also scorpion-like.

Affinities with Living Forms

Among the living forms, Horseshoe Crab has close resemblance with Crustaceans and Arachnids. Some aspects of their similarities and dissimilarities are given below:

With Crustaceans

Similarities

1. Aquatic habits and identical appearance of abdominal appendages appear to be similar features.

2. Presence of simple median and less complicated compound eyes.
3. Possession of endosternite (like Triops) provides strong evidences in favour of the affinity.

Dissimilarities

1. The respiratory organ, book-gill of Horseshoe Crab has no parallel in any Crustaceans.
2. Nauplius stage during development, a most distinguished feature of Crustacean, is not seen in Horseshoe Crab.

With Arachnids

The Xiphosurids and Arachnids have many common features. For this reason, both are included under the subphylum Chelicerata.

Similarities

1. A broad carapace covers the cephalothorax.
2. Cephalothorax bears six pairs of limbs and paired median and lateral eyes.
3. The caudal spine of Limulus resembles the post-abdominal part of scorpion.
4. Presence of structures like endosternite, genital operculum and telson in both the groups.
5. Book-gills of Limulus are supposed to have evolved from book-lungs of scorpion.
6. The suctorial pharynx, symmetrical liver, rudimentary genital glands illustrate other similar features.

Dissimilarities

1. Absence of Malpighian Tubules
2. Structure of Book-Gills

It is evident that Horseshoe Crab possesses more arthropod features and has closer relationship with Arachnida. It appears that the Horseshoe Crab, together with trilobites, originated from some common Arthropod ancestor but remained universally isolated.

G. Nautilus

Kingdom:	Animalia
Phylum:	Mollusca
Class:	Cephalopoda
Order:	Nautilida
Family:	Nautilidae

NOTES

Genus: *Nautilus*
Species: *Pompilius*

NOTES

Comments

The Nautilus is a pelagic marine mollusc. Like the squid and the octopus, the Nautilus has tentacles, but many more of them lack suckers. It also lacks the complex central nervous system of its advanced family members and has been shown to have a much poorer memory in comparison. Like the squid and the octopus, the Nautilus has tentacles, but many more of them lack suckers. It also lacks the complex central nervous system of its advanced family members and has been shown to have a much poorer memory in comparison. It can grow to a length of about 20 cm. The smooth thin shell spirals exogastrically, or above the animal, and has a pattern of brown and white.

Geographical Distribution: It is found in the Indo-Pacific Area.

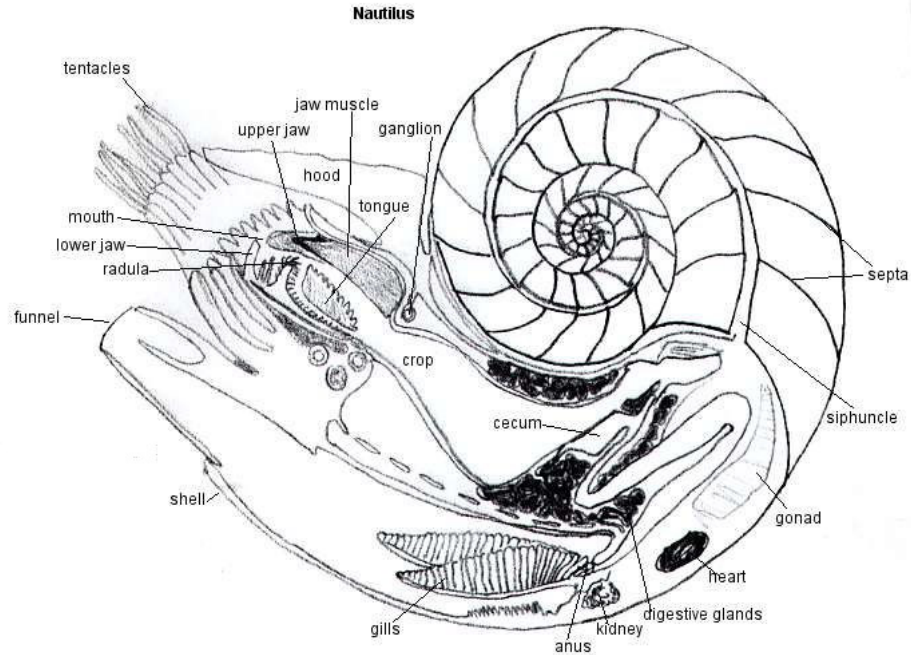

Fig. 31. Nautilus pompilius

Habit and Habitat: They live in waters up to 500 m deep along the bottom of the shores and coral reefs of the South Pacific but rise closer to the surface throughout the night. They contract the muscles while swim. They steer mostly by sensing obstacles with their tentacles or lightly bumping into them before changing course. When not swimming, it uses tentacles to pull itself along rocks. This species is nocturnal.

Reproduction: This species reproduces sexually through internal fertilization and reaches sexual maturity at age 15 to 20 years. They then lay oblong eggs

that are around 1.5 inches in length. The newly hatched chambered Nautilus has a small shell that is about 1 inch in diameter.

Food Habit: They have primitive eyes and sensitivity to light due to which they use smelling sense to detect the fishes and crabs for their diet. They also feed on carrion.

General Characteristics

1. *Nautilus pompilius* can grow to a length of about 20 cm.
2. The smooth thin shell spirals exogastrically, or above the body surface, and has a pattern of brown and white.
3. Shell is divided into different chambers that increase in size as it moves to occupy the outermost chamber of its shell. An adult may have about 30 of these chambers.
4. A tube called a siphuncle runs down the center of these chambers releasing a gas to maintain buoyancy and to keep *Nautilus pompilius* in an upright position.
5. There is a tough hood where the anterior of its body connects to the shell. Below the hood protrudes about 90 small sucker-less tentacles. Beneath, there is a funnel containing two separate lobes.
6. The eyes contain no cornea or lens.

Evolutionary Significance: This species exist somewhere between the evolutionary journey of Cephalopod's from Snail to Octopus; which has changed very little in the last 500 million years. At one point, the oceans contained hundreds of different types, but nowadays only six of it remains, all of which are found along the deep slopes bordering Indo-Pacific Coral Reefs. The family Nautilidae has its origin in the Trigonocerataceae (Centroceratina), specifically in the Syringonautilidae of the Late Triassic and continues to this day with *Nautilus*, the type genus, and its close relative, *Allonautilus*.

Primitive Character

1. They were initially straight-shelled, as in the extinct genus *Lituites*.
2. They developed in the Late Cambrian period and became a significant group of sea predators during the Ordovician period.
3. Certain species of *Nautilus*, reached over 2.5 m (8 ft) in size.
4. The other Cephalopod subclass, Coleoidea, also diverged from the Nautiloids.
5. Extinct relatives of the *Nautilus* include Ammonites, such as the Baculites and Goniatites.

NOTES

NOTES

Experiment 5: A study of Analogous and Homologous Organs.

Objective: To study the analogous and homologous organ with the help of preserved specimens.

Introduction: There are various types of evidence present which supports the theory of evolution. This evidence may range from the molecular level to the organ level. In this experiment, we will study the analogous and homologous organs of few organisms. Charles Darwin first proposed the idea of natural selection based on anatomical features of organisms. Anatomical structure can be classified as an analogous and homologous organ. **Analogous Organs** look similar but they do not share a common ancestor. They belong to different species but perform a similar function. This is an example of **Convergent Evolution**. This type of evolution occurs usually when two different species live in a similar environment in different parts of the world. Then these two unrelated species undergo various adaptations and changes which help them to survive in that particular environmental conditions. The **Homologous Organ** does not have functional similarity among them but belongs to a similar ancestor. These structural adaptations are the results of **Divergent Evolution**. Due to the natural selection process, two similar species or closely related species adapt the similarity in their structure. Divergent evolution occurs due to migration, competition for niches and also micro evolutionary changes, i.e., genetic mutation.

Apparatus and Materials Required: Preserved specimens of different organs of animals, Compound microscope.

Observations

Analogous Organ: The wings of flying insects, birds and bats. These all organisms use their wing for flying, but they do not share a common ancestor. Bats are mammal, they are not related to flying insects or birds. These organisms adapt to their environmental conditions by developing wings but this does not indicate close evolutionary relationship among them. Butterfly bears the membranous wings and is made up of the thin cuticle. Veins are present in the wings but there is no skeleton while there is skeletal support present in bats and birds.

Another example of the analogous organ is the fins of shark and dolphin. Shark belongs to fish family while dolphin belongs to mammals. Both fishes live in a similar environment and use their fins for a swim and move within the aquatic environment.

NOTES

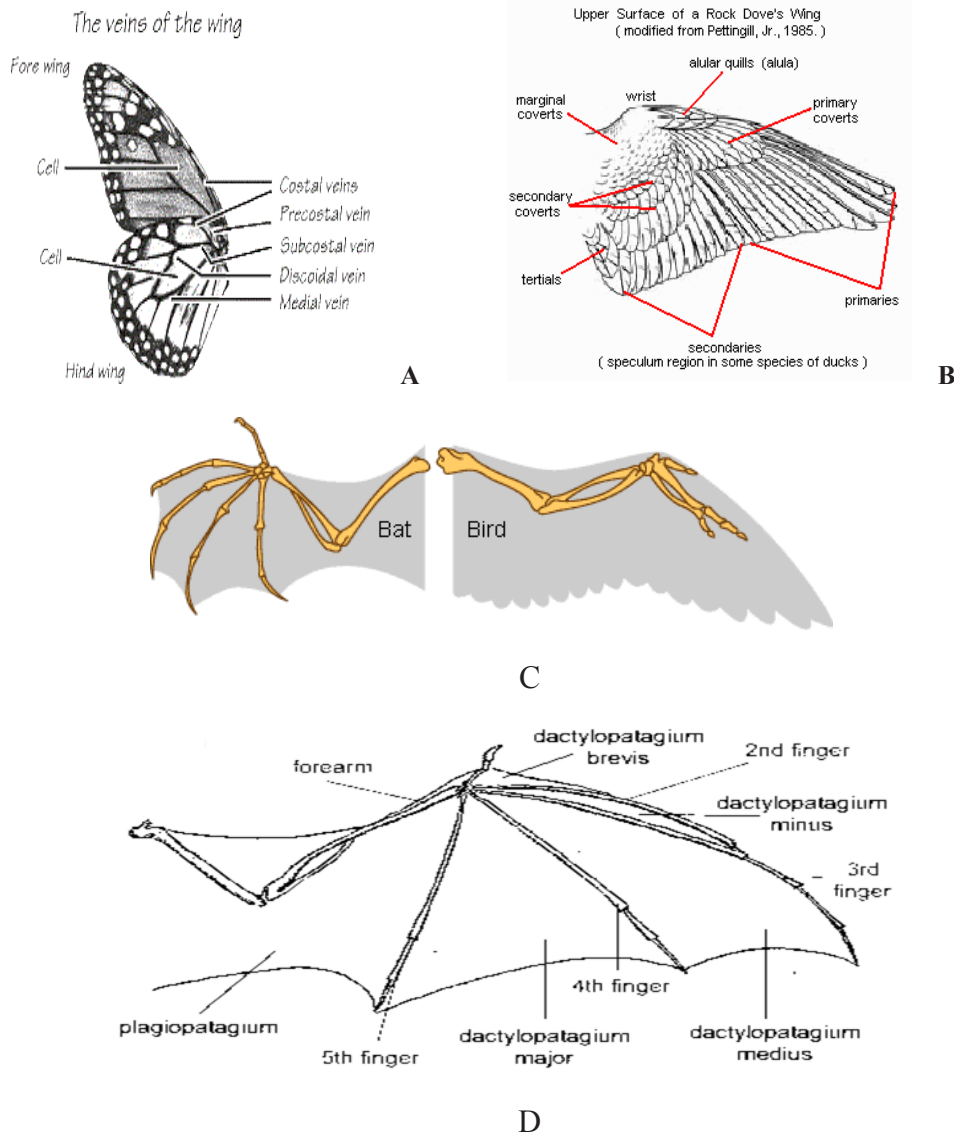

Fig. 32. Analogous Organs of A. Fish B. Bird C. Bony Structure of Bat and Bird D. Bat

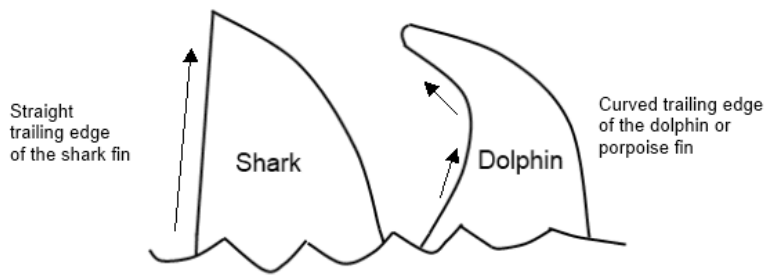

Fig. 33. Wings of Shark and Dolphin

NOTES

Homologous Organ

If we examine the wings of flying mammal (bat) and forelimb of man, they are dissimilar in their external structure but have similar bone structure. For example, both bat and man has arm bone (humerus), hand bones (radius ulna), wrist bones (carpals), palm bones (metacarpals), and fingers (phalanges). They are anatomically similar but perform a different function. Bat uses his wings for flying and man uses his forelimb arm for handling. Thus these are homologous organs.

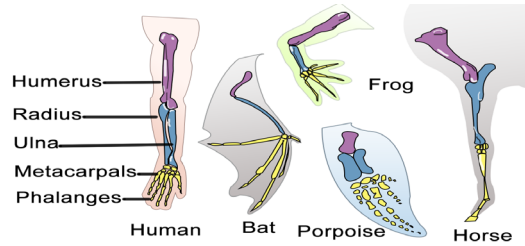

Fig. 34. The Homologous Body Organs of Various Organisms

Experiment 6. Fossil

Objective: To study the fossils of *Archaeopteryx lithographica*.

Introduction: A fossil is a naturally preserved remains of animal or plants that existed in the geologic past. Fossils are of two types: body fossils which include the remains of organisms and trace fossils are the signs or footprints which indicate that the organisms were present. *Archaeopteryx lithographica* represents the link between birds and the dinosaur *Compsognathus longipes*. It is a transitional form that links the avian and reptilian lines. In 1860, in Germany, it is also referred as *Urvogel* means ‘Original Bird’. *Archaeopteryx* is a combination of two ancient Greek words ‘*Archaios*’ means ‘Ancient’ and ‘*Pteryx*’ means ‘Feather’. It exists around 150 million years ago during the early Tithonian stage.

Material Required: Preserved Specimen.

Classification

Kingdom	Animalia
Phylum	Chordata
Class	Archosauria
Order	Saurischia
Suborder	Theropoda
Family	Archaeopteridae
Genus	<i>Archaeopteryx</i>
Species	<i>Lithographica</i>

NOTES

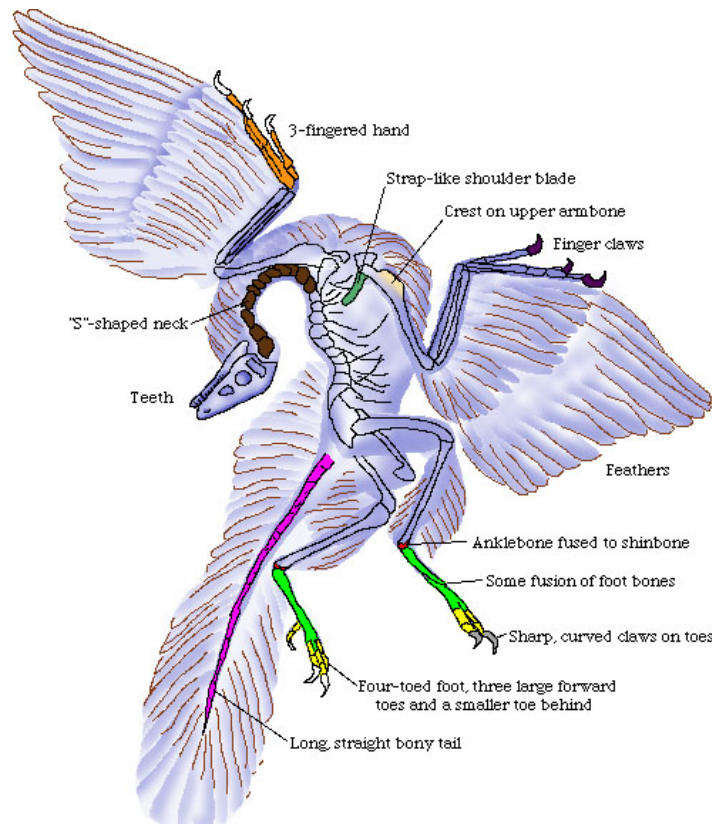

Fig. 35. Fossil of *Archaeopteryx lithographica*

Observations

1. There is a presence of hollow nerve chord ending in the brain.
2. It has well developed jaws along with socket-set sharp teeth.
3. It also has flat sternum (breastbone) and belly ribs (gastralia).
4. It has a presence of long bony tail structure similar to its body length up to 20 inches.
5. It has well developed broad hollow wings along with feathers having rounded ends.
6. They have claws with fused fingers and hyperextensible second toes.
7. It also bears a wishbone, a breastbone, hollow, thin-walled bones, air sacs in the backbones.
8. They possess a wingspan of about 1.5 feet (0.5 m) and body length of about 1 foot (30 cm) from beak to tail.

Conclusion: These features showed that *Archaeopteryx lithographica* is a transitional fossil link between non-avian dinosaurs and birds. Thus, *Archaeopteryx lithographica* plays an important role, not only in the study of the origin of birds, but in the study of dinosaurs.

NOTES

Experiment 7. Mimicry and Colouration.

Objective: To study the various types of mimicry and colouration.

Introduction: Mimicry is the phenomenon of close resemblance of one organism to other organisms either living or non-living, in order to protect themselves from danger. Mimicry is derived from Latin word '*mimicus*' means 'imitation'. The organism which mimics is known as mimic and the one whom it resembles is called model. **Henry Bates** is the first English naturalist who first observed and gave the concept of mimicry in 1862 A.D., therefore, this phenomenon also called **Batesian mimicry**. Mimicry occurs between the organisms of two different species or same. It either provides an advantage to both mimicus and model known as the mutualism or can be a detrimental to one known as the competitive. There are three different types of mimicry.

I. **Defensive or Protective Mimicry:** In this type of mimicry, warning signals of two or more species resemble each other. It is helpful in order to avoid the harmful or deceiving enemies. This type of mimicry is usually adopted by prey in order to protect themselves from a predator. Prey usually camouflage by its close resemblance to a dead or dull object which is of no interest to its predator. This further divided into two types: **Concealing** mimicry and **Warning** mimicry.

- a. **Concealing Mimicry:** It is also known as cryptive type protective mimicry. It is a defensive strategy of the palatable organism in which it resembles to its surrounding environment so that it cannot be easily detected by its predators. Here the mimic is defenseless in nature but has anti-predatory marks like model which has a defense mechanism against the predator. This will increase its chances of the survival. For example, the body appendages of *Carausius morasus* (Stick Insect) are long, slender like thin and dry branches. **A.R. Wallance** also reported that the body of *Kallima paralecta* (Dead-Leaf Butterfly) looks like a dead and dry leaf while resting on an oak tree.



Carausius morasus (Stick Insect)



Kallima paralecta (Dead-Leaf Butterfly)

- b. **Warning Mimicry:** In this type of protective mimicry, the mimic resembles a distasteful or poisonous organism (a palatable species). This is commonly called **Batesian mimicry**. For example, *Bosilarchia archippus* (Viceroy Butterfly) resembles a distasteful *Donascus plexippus* (Monarch Butterfly).



Bosilarchia archippus (Viceroy Butterfly)



Donascus plexippus (Monarch Butterfly)

When two or more unpalatable and related species resemble each other, then this is called **Mullerian Mimicry**. In this, mimic shares the same defensive mechanism as by model. This was first observed by Fritz Muller. For example, *Donascus plexippus* (Monarch Butterfly) and *Danaus gilippus* (Queen Butterfly) share colouration pattern and display behaviour.



Donascus plexippus (Monarch Butterfly)

NOTES

NOTES



Danaus gilippus (Queen Butterfly)

II. **Aggressive Mimicry:** This type of mimicry is generally employed by a predator where they change their colour and resemble the harmless species in order to deceive the potential prey. It is opposite in principal to the defensive mimicry. This can also be compared with the story of the *wolf in sheep's clothing*. It is again of two types: **Concealing** and **Alluring**.

- a. **Concealing Aggressive Mimicry:** The predator camouflage with their surrounding environment in order to remain unnoticed from the prey. For example, *Mantis religiosa* (Praying Mantis). Most species of flower mantis are in the family Hymenopodidae. The Orchid Mantis, *Hymenopus coronatus*, of South-East Asia mimics an orchid flower. It remains motionless on the plant until the prey arrive; the same camouflage also protects it from predators.



Hymenopus coronatus (Orchid Mantis)

- b. **Alluring Aggressive Mimicry:** During this mimicry, the predator resembles the object which is of interest to the prey. For example,

the Alligator Snapping Turtle (*Macrochelys temminckii*) is a well-camouflaged ambush predator. Its tongue bears a conspicuous pink coloured extension that resembles a worm and can be wriggled around, fish that try to eat the 'worm' are themselves eaten by the turtle. Similarly, some snakes employ the caudal luring (using the tail) or lingual luring (using the tongue) to entice small vertebrates into striking range.

NOTES



Macrochelys temminckii (Alligator Snapping Turtle)

III. **Feigning Death or Conscious Mimicry:** Some organisms exhibit conscious the imitation after sensing the danger and behave like a dead animal. For example, *Didelphis*, (American Opossum) when attacked by the enemy, behave like a dead. Hard-bodied beetles drop down like a pebble when attacked or is about to be seized.



Didelphimorphia (American Opossum)

Conclusion: Mimicry and colouration are of evolutionary importance and increases the survival of organisms.

NOTES

GENETICS

Experiment 1. Klinefelter Syndrome, Turner Syndrome, Down Syndrome, Cri-Du-Chat Syndrome.

Objective: To study about Klinefelter Syndrome, Turner Syndrome, Down Syndrome, Cri-Du-Chat Syndrome

KLINFELTER SYNDROME

Causes

1. Klinefelter syndrome is a sex chromosome disorder in boys and men that results from the presence of an extra X chromosome in cells. People typically have 46 chromosomes in each cell, two of which are the sex chromosomes.
2. Females have two X chromosomes (46, XX), and males have one X and one Y chromosome (46, XY).
3. Most often, boys and men with Klinefelter syndrome have the usual X and Y chromosomes, plus one extra X chromosome, for a total of 47 chromosomes (47, XXY).

Symptoms

1. Klinefelter syndrome is a chromosomal condition found in both boys and men that can affect physical and intellectual development.
2. Its signs and symptoms vary among affected individuals. In some cases, the features of the condition are so mild that the condition is not diagnosed until puberty or adulthood, and researchers believe that some affected men and boys are never diagnosed.
3. Boys and men with Klinefelter syndrome typically have smaller testes that produce a reduced amount of testosterone hormone. Testosterone is the hormone that directs male sexual development before birth and during puberty.
4. Without any treatment, the shortage of testosterone can lead to delayed or incomplete puberty, breast enlargement (gynecomastia), and a reduced amount of facial and body hair. As a result of the small testes and decreased hormone production, affected males are unable to father biological children (infertile) without assisted reproductive technologies.
5. Some affected individuals also have differences in their genitalia, including undescended testes, the opening of the urethra on the underside of the penis (hypospadias), or an unusually small penis (micropenis).
6. Other physical changes associated with Klinefelter syndrome are usually subtle. Older children and adults with the condition tend to be somewhat taller than their peers.

7. Other differences can include abnormal fusion of certain bones in the forearm (Radioulnar Synostosis), curved pinky fingers (fifth finger clinodactyly), and flat feet (Pes Planus).
8. Children with Klinefelter syndrome may have weak muscle tone (hypotonia) and problems with coordination that delay the development of motor skills, such as sitting, standing, and walking.
9. Affected boys often have learning disabilities, problems with reading, and mild delays in speech and language development.
10. Boys and men with Klinefelter syndrome tend to have better receptive language skills (the ability to understand speech) than expressive language skills (vocabulary and the production of speech) and may have difficulty communicating and expressing themselves.
11. They tend to have anxiety, impaired social skills, a short attention span, and limited problem-solving skills (executive functioning).

NOTES

TURNER SYNDROME

Causes

1. Turner syndrome is related to the X chromosome, which is one of the two sex chromosomes. Turner syndrome results when one normal X chromosome is present in a female's cells and the other sex chromosome is missing or gets structurally altered. The missing genetic material thus affects developmental processes before and after birth.
2. About half of individuals which gets affected with Turner syndrome have monosomy X, which implies that each cell in the individual's body has only one copy of the X chromosome instead of the usual two sex chromosomes.
3. Turner syndrome can also occur if one of the sex chromosomes is partially missing or rearranged rather than completely absent. Some women affected with Turner syndrome have a chromosomal change in only some of their cells, which is known as mosaicism. Women with Turner syndrome caused by X chromosome mosaicism are said to have mosaic Turner syndrome.
4. Turner syndrome is not inherited, when this condition results from monosomy X, the chromosomal abnormality occurs as a random event during the formation of reproductive cells (eggs and sperm) in the affected person's parent.
5. An error in cell division called nondisjunction can result in reproductive cells with an abnormal number of chromosomes.
6. For example, an egg or sperm cell may lose a sex chromosome as a result of nondisjunction. If one of these atypical reproductive cells contributes to the genetic makeup of a child, the child will have a

single X chromosome in each cell and will be missing the other sex chromosome.

NOTES

Symptoms

1. Turner syndrome is a chromosomal condition that affects the process of development in females. The most common feature of this syndrome is short stature, which becomes evident by the age of 5.
2. The occurrence of early loss of ovarian is also another very common feature. The ovaries start to develop normally at first, but then the egg cells (oocytes) usually die prematurely and most ovarian tissue degenerates before birth.
3. Many affected girls do not undergo puberty unless they receive hormone therapy, and most are unable to conceive. A very small percentage of females affected with Turner syndrome retain their normal ovarian function throughout young adulthood.
4. About 30 percent of females suffering from Turner syndrome have extra folds of skin on the neck also known as webbed neck, a low hairline at the back of the neck, puffiness or swelling of the hands and feet, skeletal abnormalities, or kidney problems.
5. One third to one-half population of individuals with Turner syndrome are born either with a heart defect, such as a narrowing of the large artery leaving the heart or with the abnormalities of the valve that connects the aorta with the heart.
6. Most girls and women suffering from Turner syndrome have normal intelligence, developmental delays, nonverbal learning disabilities, and behavioural problems are possible, although these characteristics vary among the affected individuals.

DOWN SYNDROME

Causes

1. Down syndrome occurs from trisomy 21, which means that each cell in the body has three copies of chromosome 21 instead of the usual two copies.
2. Having extra copies of genes on chromosome 21 disrupts the course of normal development, thus leads to the characteristic features of Down syndrome along with the increased risk of health problems associated with this condition.
3. Down syndrome is not inherited. The condition is caused by trisomy of 21, the chromosomal abnormality occurs as a random event during the formation of reproductive cells in a parent. The abnormality mainly occurs in egg cells, but it can rarely occur in sperm cells.

4. An error in the process of cell division called nondisjunction results in a reproductive cell with an abnormal number of chromosomes.
5. An egg or sperm cell may gain an extra copy of chromosome 21. If one of these atypical reproductive cells contributes to the genetic makeup of a child, the child will have an extra chromosome 21 in each of the body's cells.

NOTES

Symptoms

1. Down syndrome is a chromosomal condition that is associated with intellectual disability, the presence of a characteristic facial appearance, and weak muscle tone (hypotonia) during the period of infancy. Individuals having Down syndrome experience cognitive delays, but their intellectual disability is usually mild to moderate.
2. People with Down syndrome may experience a variety of birth defects. They majorly experience a heart defect, digestive abnormalities, such as the blockage of the intestine.
3. People affected with Down syndrome have an increased risk of developing several medical conditions, such as increased risk of hearing and vision problems, gastroesophageal reflux, which is a backflow of acidic stomach contents into the esophagus, and celiac disease, which is an intolerance of a wheat protein called gluten.
4. 15 percent of people affected with Down syndrome have an underactive thyroid gland (hypothyroidism). A small percentage of children suffering from the Down syndrome tends to develop Leukemia.
5. Children with Down syndrome often report of delayed development and behavioural problems. The individuals affected speech and language develop slowly as compared to children not suffering from the Down syndrome.
6. Behavioural issues include attention problems, obsessive/compulsive behaviour, and stubbornness or tantrums.
7. A small percentage of people affected with Down syndrome are diagnosed with a developmental condition called Autism Spectrum Disorders, which affect their communication and social interaction skills.
8. Down syndrome can also be associated with a high risk of developing Alzheimer disease, a brain disorder that results in a gradual loss of memory, judgment, and ability to function.
9. People affected with Down syndrome experience a gradual decline in cognition as they age, starting around the age of 50.
10. Half of the adults affected with Down syndrome tend to develop Alzheimer disease.

NOTES

CRI-DU-CHAT SYNDROME

Causes

1. It is also called a Cat's Cry Syndrome, also known as 5p- (5p minus) syndrome, is a chromosomal condition where a piece of chromosome 5 is missing.
2. Cri-Du-Chat syndrome is caused by a deletion of the end of the short (p) arm of chromosome 5. This chromosomal change is written as 5p-.
3. The size of the deletion of the chromosome varies among affected individuals, various studies suggest that larger deletions tend to result in more severe intellectual disability and developmental delay than smaller deletions.
4. The deletion occurs most often as a random event during the formation of reproductive cells (eggs or sperm) or in early fetal development.
5. Affected people typically have no history of the disorder in their family.
6. Individuals with the Cri-Du-Chat syndrome who inherit an unbalanced translocation are missing genetic material from the short arm of chromosome 5, which results in the intellectual disability and health problems characteristic of this disorder.

Symptoms

1. Infants with this condition often are known to have a high-pitched cry that sounds like that of a cat.
2. The disorder is characterized by intellectual disability and delay in the development process, small head size also known as microcephaly, low birth weight, and weak muscle tone in infancy.
3. Affected individuals also have distinctive facial features, including widely set eyes (hypertelorism), low-set ears, a small jaw, and a rounded face.

They also show wide set eyes, along with the downward slant to the eyes.

Experiment 2. Pedigree Analysis using Charts and Data.

Objective: To study about Pedigree analysis using charts and data.

Theory

Scientists devised a different approach, called **Pedigree Analysis**, used to study the inheritance of genes in humans. Pedigree analysis is also useful when studying any population when progeny data from several generations is limited. Pedigree analysis is also useful when studying species with a long generation time.

A series of symbols are used to represent different aspects of a pedigree. Below are the principal symbols used when drawing a pedigree diagram.

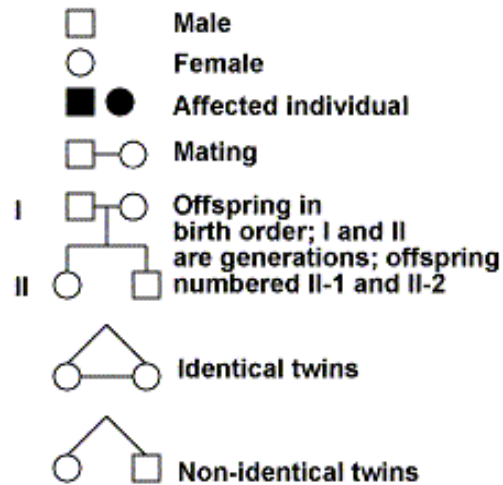

NOTES

Representations of Pedigree Chart

Once the phenotypic data is collected from several generations and then the pedigree is drawn, careful analysis of the pedigree will allow you to determine whether the trait is dominant or recessive. Here are some rules to follow.

For Those Traits Exhibiting Dominant Gene Action

- Affected individuals have at least one affected parent.
- The phenotype generally appears in every generation.
- Two unaffected parents only have unaffected offspring.

The following is the pedigree of a trait controlled by dominant gene action.

Dominant Pedigree

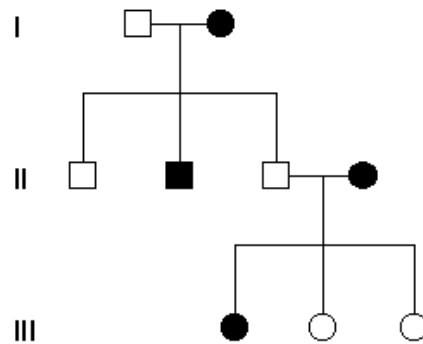

For Those Traits Exhibiting Recessive Gene Action

- Unaffected parents can have affected offspring.
- Affected progeny are both male and female.

The following is the pedigree of a trait controlled by recessive gene action.

Recessive Pedigree

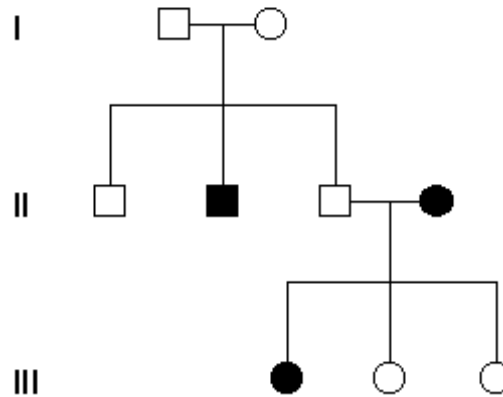

NOTES

In The Case of Dominant Genes

- One or both the parents have the disorder.
- It expresses itself in every generation.
- The disorder is common in the pedigree.
- The genotype is either homozygous (BB) or heterozygous (Bb).
- It affects one-half of the children.

In The Case of Recessive Genes

- Neither of the parents may have the disorder.
- The disorder is rare in the pedigree.
- Both parents are either heterozygous or homozygous recessive.
- The disorder skips generations.

Experiment 3. Human Karyotyping and Chromosomal Abnormalities.

Objective: To study about human karyotyping and chromosomal abnormalities.

Human Karyotyping

Theory: A karyotype in simple words is a picture of a person's chromosomes. In order to study it, the chromosomes are isolated, stained, and examined under the microscope. Then a picture of the chromosomes is taken with the help of a microscope. Then, the picture of the chromosomes is cut and rearranged on the basis of chromosome's size. The chromosomes are arranged to start from largest to smallest.

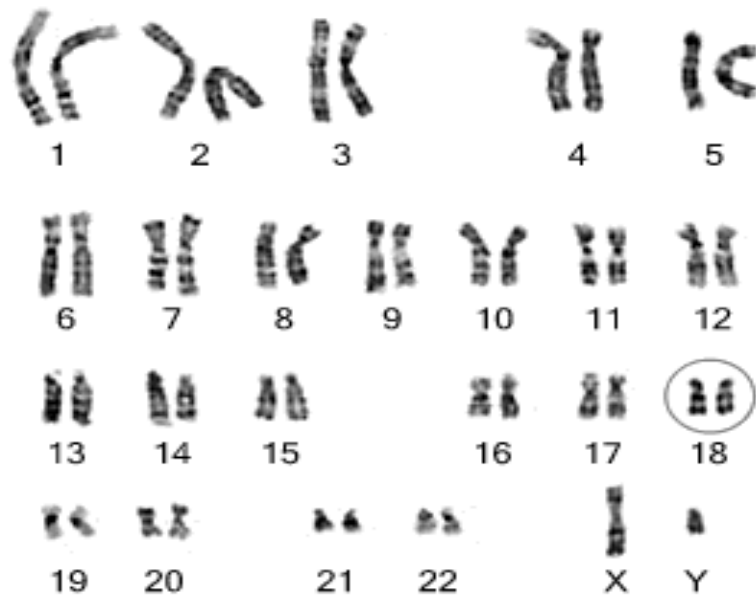

NOTES

There are total of 22 pairs of chromosomes called **Autosomes**. The 23rd pair of chromosomes present is called the **Sex chromosomes**. They determine an individual's gender. There are two X chromosomes present in the females, and there is a presence of an X and a Y chromosome in males. In 1960 the classification of chromosomes was done in seven groups on the basis of size and relative centromere position based on the '**Denver System**'. Modern banding techniques allow each chromosome in the Karyotype to be distinguished individually.

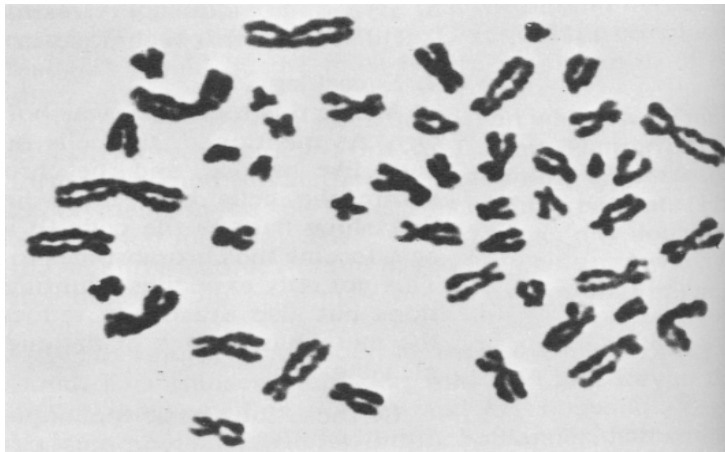

1. The above is a photograph of the 46 human chromosomes in a somatic cell, arrested in metaphase.
2. Normal male Karyotype, a Cytogeneticist has lined these chromosomes up, matching homologues up and arranging them by size.

NOTES

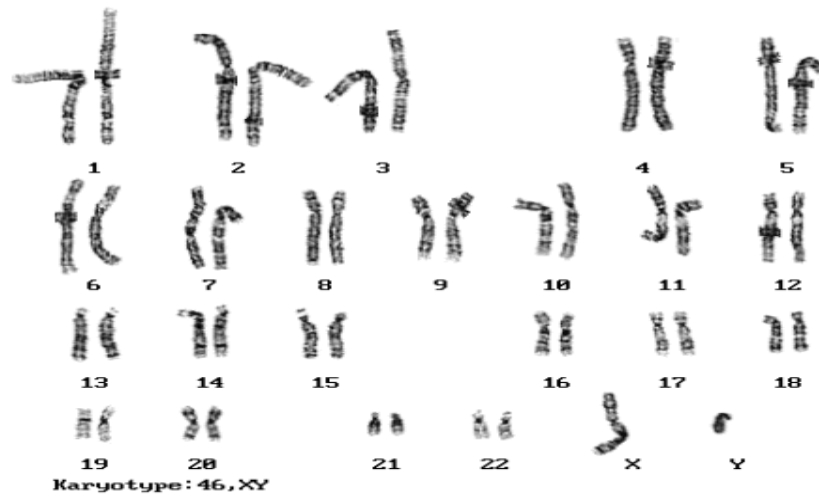

3. Normal Female Karyotype

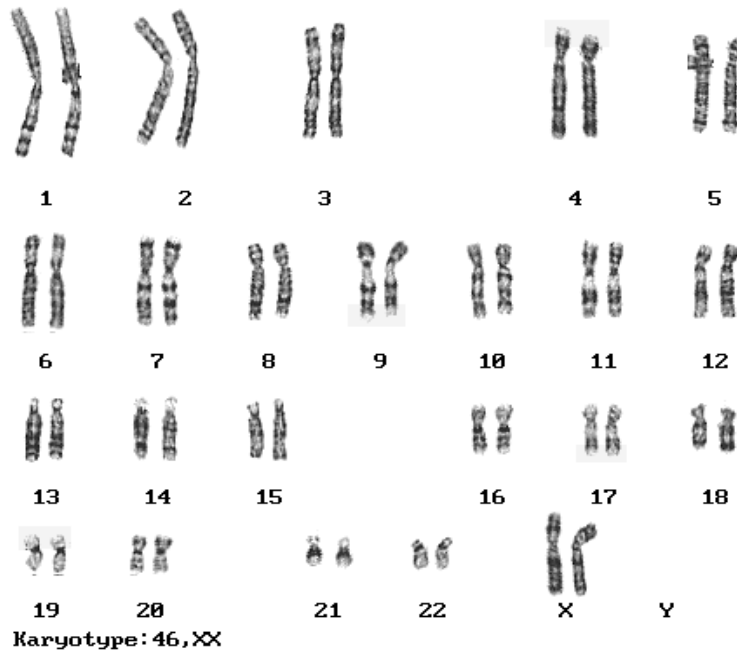

II. Alterations in Chromosome Number

Nondisjunction occurs when either *homologues fail to separate* during Anaphase I of Meiosis or *sister chromatids fail to separate* during Anaphase II. The result is that one gamete has 2 copies of one chromosome and the other has no copy of that chromosome, while the other chromosomes are distributed normally.

If either of these gametes unites with another during fertilization, the result is **Aneuploidy** (Abnormal Chromosome Number).

- A **Trisomic** cell has one extra chromosome ($2n + 1$) = Trisomy 21. **Polyplidy** refers to the condition of having **three** homologous chromosomes rather than two.
- A **Monosomic** cell has one missing chromosome ($2n - 1$) = usually lethal except for one known in humans, Turner's syndrome (Monosomy XO).

NOTES

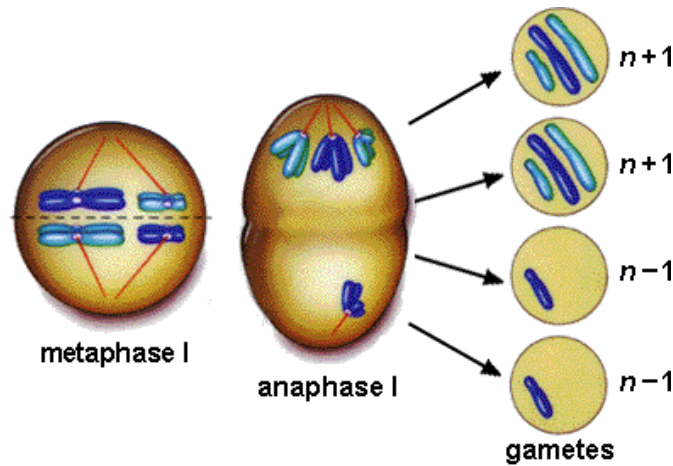

The frequency of nondisjunction is quite high in humans, but the results are usually so devastating to the growing zygote that miscarriage occurs very early in the pregnancy.

If the individual survives, he or she usually has a set of symptoms - a syndrome - caused by the abnormal dose of each gene product from that chromosome.

1. Human Disorders due to Chromosome Alterations in Autosomes (Chromosomes 1-22). There only 3 trisomies that result in a baby that can survive for a time after birth, the others are too devastating and the baby usually dies in utero.

A. Down Syndrome (Trisomy 21): The result of an extra copy of chromosome 21. People with Down syndrome are 47, 21+. Down syndrome affects 1:700 children and alters the child's phenotype either moderately or severely:

- Characteristic facial features, short stature, heart defects.
- Susceptibility to respiratory disease, shorter lifespan.
- Prone to developing early Alzheimer's and Leukemia.
- Often sexually underdeveloped and sterile, usually some degree of mental retardation.
- Down syndrome is correlated with age of mother but can also be the result of nondisjunction of the father's chromosome 21.

NOTES



Karyotype of a Boy with Down Syndrome

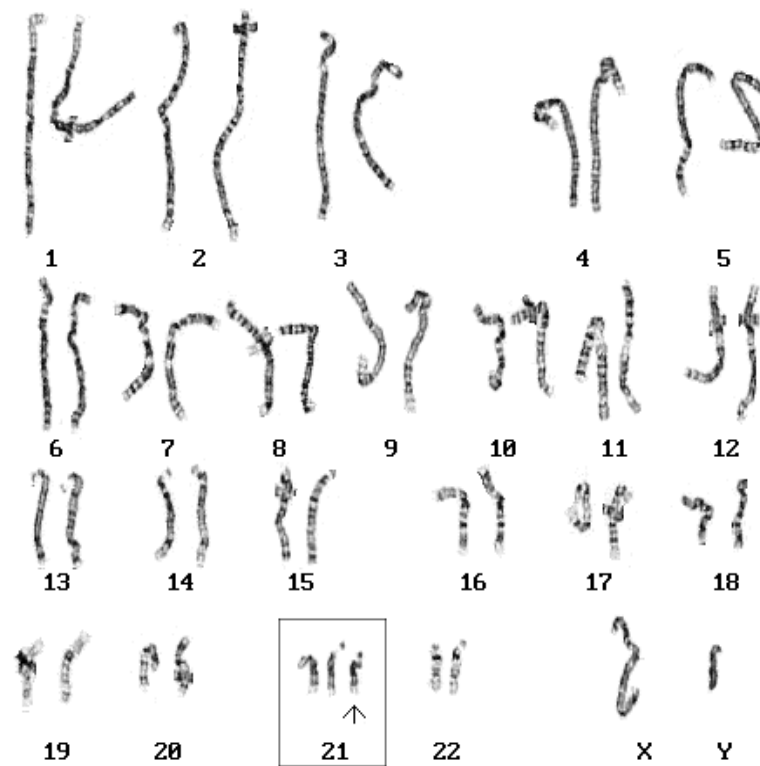

B. Patau Syndrome (Trisomy 13): Serious eye, brain, circulatory defects as well as cleft palate. 1:5000 live births. Children rarely live more than a few months.

NOTES

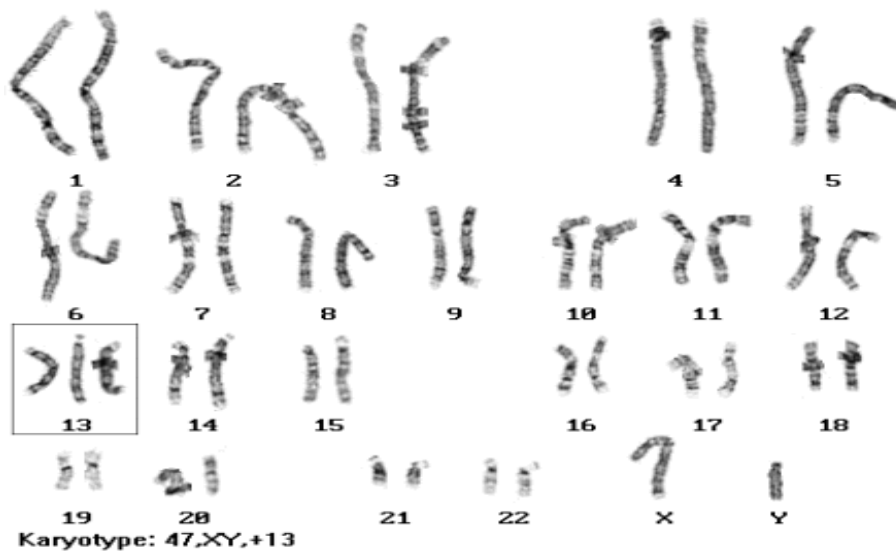

C. Edward's Syndrome (Trisomy 18): Almost every organ system affected 1:10,000 live births. Children with full Trisomy 18 generally do not live more than a few months.

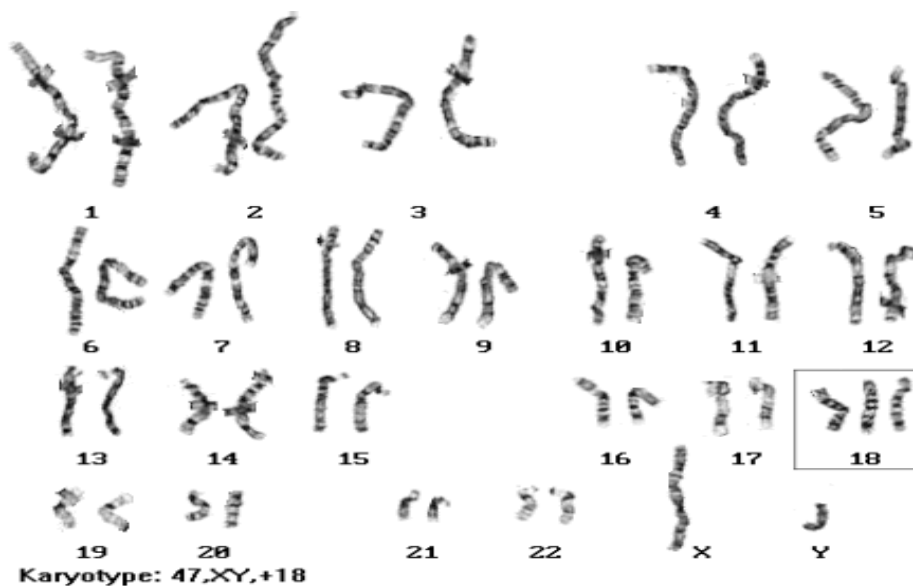

2. Nondisjunction of the Sex Chromosomes (X or Y Chromosome): Can be fatal, but many people have these karyotypes and are just fine.

A. Klinefelter Syndrome: 47,XXY males. Male sex organs; unusually small testes, sterile. Breast enlargement and other feminine body characteristics. Normal intelligence.

NOTES

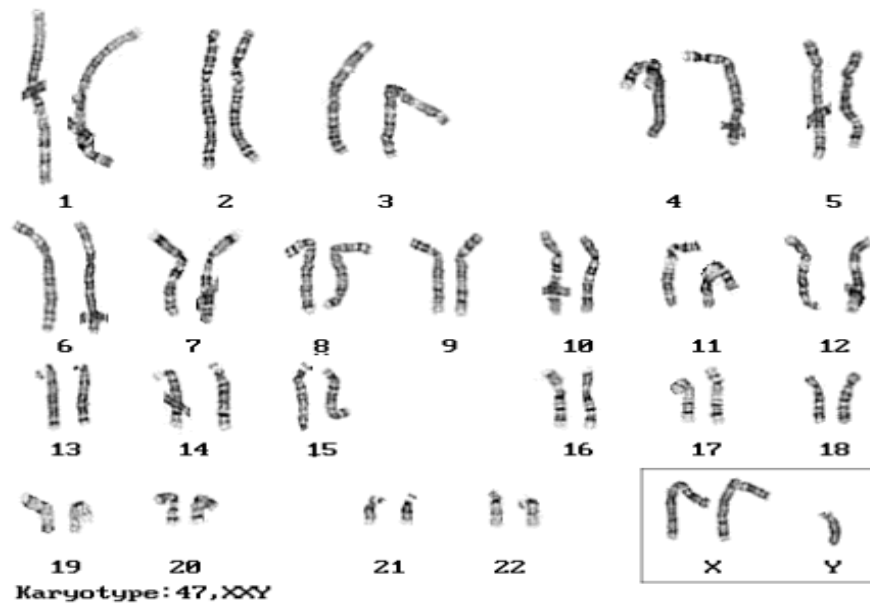

B. 47, XYY Males: Individuals are somewhat taller than average and often have below normal intelligence. At one time (~ the 1970s), it was thought that these men were likely to be criminally aggressive, but this hypothesis has been **disproven** over time.

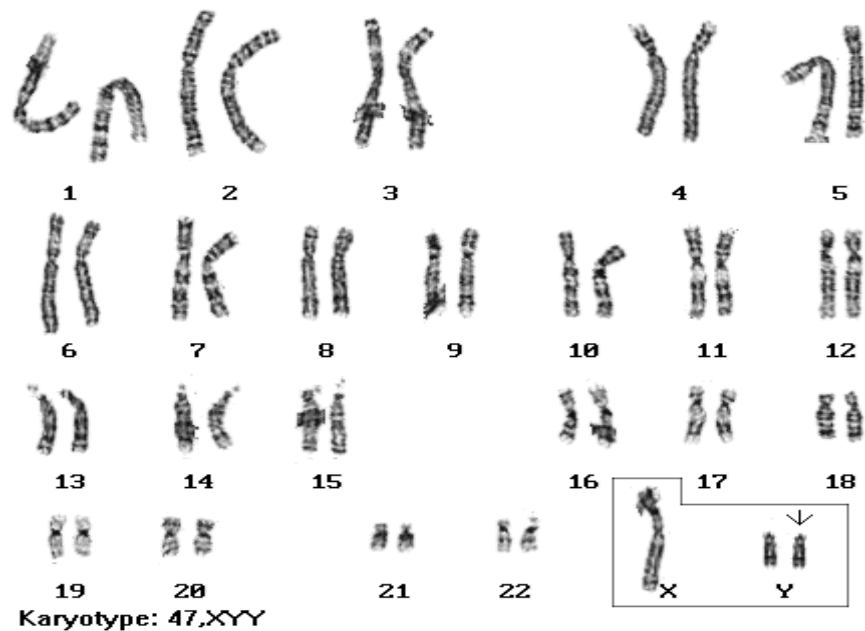

3. Trisomy X: 47, XXX Females. 1:1000 live births - healthy and fertile - usually cannot be distinguished from normal female except by Karyotype.

NOTES

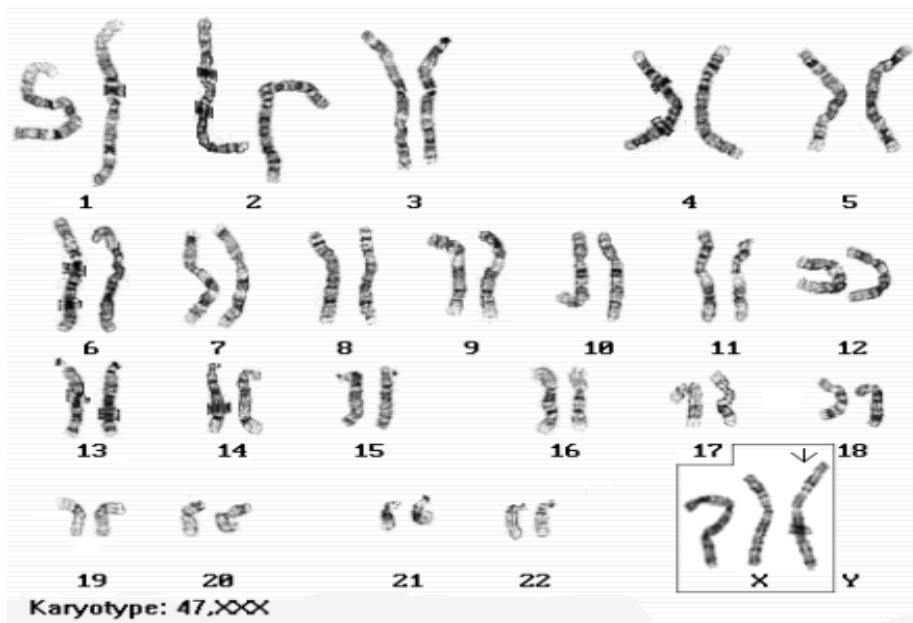

4. Monosomy X (Turner's Syndrome): 1:5000 live births, the only viable monosomy in humans - women with Turner's have only 45 chromosomes. XO individuals are genetically female, however, they do not mature sexually during puberty and are sterile. Short stature and normal intelligence. 98% of these foetuses die before birth.

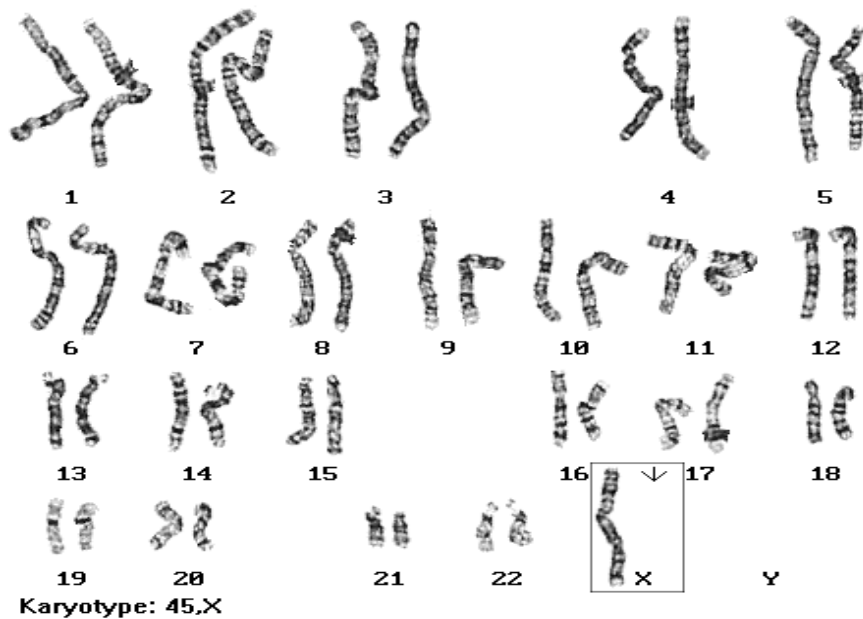

III. Alterations in Chromosome Structure

Sometimes, chromosomes **break**, leading to following 4 types of changes in chromosome structure:

NOTES

1. Deletion: A portion of one chromosome is **lost** during cell division. That chromosome is now missing certain genes. When this chromosome is passed on to offspring the result is usually lethal due to missing genes.

Example – Cri-Du-Chat (Cry of the Cat) Syndrome: A specific deletion of a small portion of chromosome 5; these children have severe mental retardation, a small head with unusual facial features, and a cry that sounds like a distressed cat.

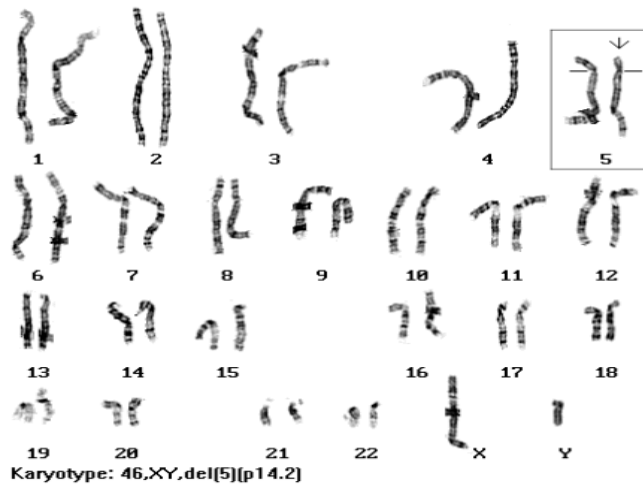

2. Duplication: If the fragment joins the homologous chromosome, then that region is **repeated**.

Example - Fragile X: The most common form of mental retardation. The X chromosome of some people is unusually fragile at one tip - seen 'Hanging by a Thread' under a microscope. Most people have 29 'repeats' at this end of their X-chromosome, those with Fragile X have over **700** repeats due to duplications. Affects 1:1500 males, 1:2500 females.

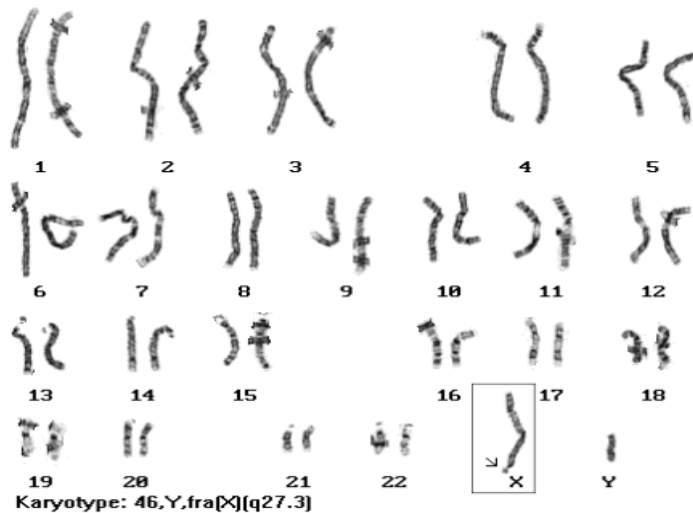

NOTES

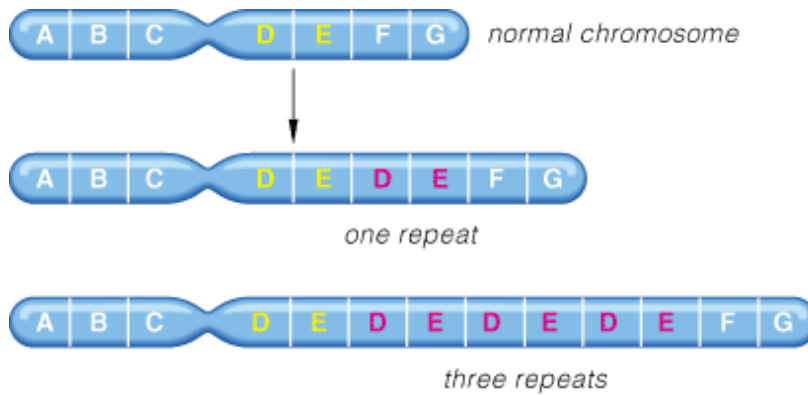

3. **Translocation:** A fragment of a chromosome is *moved* (translocated) from one chromosome to another - joins a non-homologous chromosome. The balance of genes is still normal (nothing has been gained or lost) but can alter phenotype as it places genes in a new environment. Can also cause difficulties in egg or sperm development and normal development of a zygote. Acute Myelogenous Leukemia is caused by this translocation.

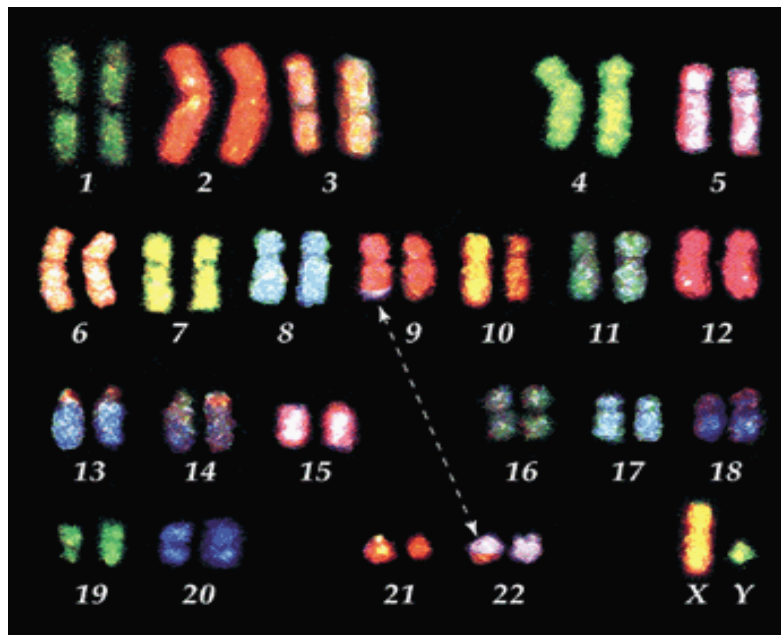

Procedure

- Cells (from blood, amniotic fluid, etc.) are grown in *in vitro* (in a cell culture dish) in order to increase their number.
- Cell division was then arrested in the metaphase stage with Colchicines.

NOTES

- Cells were then centrifuged and lysed in order to release chromosomes.
- Chromosomes were then stained, photographed, and grouped by size and banding patterns.

Observations: Coloured chromosomes were observed with different banding pattern.

Experiment No 4: Hardy Weinberg Equation and Questions

Objective: To study about Hardy Weinberg Equation and Questions

Theory

Hardy-Weinberg Law is an algebraic equation that tells us about the genetic equilibrium within a population. It was discovered in 1908 by Wilhelm Weinberg, a German physician, and Godfrey Harold Hardy, a British mathematician.

The science of the population genetics is based on Hardy Weinberg principle, which may be defined as in a large, random-mating population, the proportion of dominant and recessive genes present tends to remain constant from generation to generation unless outside forces act to change it. The force that acts from outside that can disrupt the natural equilibrium are selection, mutation, and migration. The genes tend to remain constant in such a way that even the rarest forms of genes, which one would assume would disappear, are preserved. A medical geneticist uses the Hardy-Weinberg law so as to calculate the probability of human matings that results in defective offspring. This law can also be used in order to determine whether the number of harmful mutations in a population is increasing due to radiation from industrial processes, medical techniques. The discovery of Hardy Weinberg law was significant in affirming natural selection working as the primary mechanism of evolution. A variation that occurs in the Individual occurs due to the various genetic combinations that results from the random mating of individuals, but non-random, or selective, mating must take place for the process of natural selections to take place.

Gene Frequency is the proportion of an allele in the gene pool as compared with other alleles at the same locus. It is calculated by dividing the number of a particular gene by the total number of genes present in the population. For example, if there are 100 individuals in a population, 40 of them being dominant MM, 40 heterozygous Mm and 20 recessive mm, the frequency of the dominant gene M, which is depicted by P, would be $40+20/100=0.6$ and the frequency of the recessive gene m, denoted by q, would be $20+20/100=0.4$. $P+q$ should always be 1.0 and hence when the frequency of one gene increases, that of the other must decrease.

Genotype Frequency is the total number of one kind of individuals in a population exhibiting similar characters (genotype) with respect to the locus. It can be determined by dividing the number of individuals having one kind of genotype by the total number of individuals in a population.

Therefore, in the above example, the genotype frequency of the dominant homozygotes MM will be $D/N=40/100=0.4$, that of Mm will be $H/N=40/100=0.4$ and that of recessive mm will be $r/N=20/100=0.2$, where N=total number of individuals and D, H and r denote dominant, heterozygous and recessive respectively.

The next generation will have the following composition: 0.25 MM + 0.5 Mm + 0.25 mm, this can also be written as: 1 MM + 2 Mm + 1 mm OR $M^2 + 2 Mm + m^2$. If P is the frequency of gene M and q is the frequency of gene m, then the above equation can be written as $P^2 + 2Pq + q^2 = (P+q)^2$. This is called the **Hardy-Weinberg's equation**.

Example 1. Let us presume there is population of rats, which has 50% brown (MM) and 50% white (mm) individuals. The gene frequencies will be $P=0.5$ and $q=0.5$ ($P+q=1.0$). Both gene frequencies and genotype frequencies are same here. Now let us substitute the figures in the Hardy-Weinberg's equation as follows:

$$P^2 + 2Pq + q^2 = (0.5)^2 + 2 \cdot (0.5)(0.5) + (0.5)^2 = 0.25 + 0.5 + 0.25$$

The genotype frequency in F_1 generation will be—25% MM + 50% Mm + 25% mm but the gene frequencies will still remain as $P=0.5$ and $q=0.5$, that is they remain unchanged even in the next generation.

In this example, dominant gene equals the recessive gene but in nature usually, the recessive gene is far less in number. Will the gene frequencies remain unchanged even in such a case is illustrated by the following example.

Example 2. If in a population of rats 16% individuals are recessive white and rest are brown, what will be the composition of the population (i.e., find out the value of MM and Mm)?

If white individuals are 16% (mm), then $m^2 = 16$ OR $q^2 = 0.16$; $q =$ Square Root of 0.16; $q = 0.4$.

As we have found out the value of q, the value of P can be known by $P=1.0-q$; or $1.0-0.4$ or $P=0.6$.

Now to calculate the heterozygous Mm rats— $2Pq = 2.(0.6)(0.4) = 0.48$, which means 48% of rats were heterozygous brown (Mm), and since we know that 16% were white (mm), the rest of the population has to be MM or homozygous brown ($100-48+16 = 16\%$). The final composition of the population will be 36%MM + 48%Mm + 16%mm.

NOTES

MICROBIOLOGY

NOTES

Experiment 1: Enumeration of Bacteria and Fungi.

Objective: To study how to enumerate the bacteria and fungi.

Introduction: In unicellular organisms such as bacteria and fungi, cell reproduction leads to the production in the entire organisms. In order to determine the rate of microbial growth, it is necessary to determine the numbers of microorganisms or to enumerate them. There are various methods known for the purpose of enumerating the bacteria and fungi population. Each method has its own advantages and disadvantages. These methods have their own peculiar way to calculating microbial density for the given sample from the raw data obtained. Colony Forming Unit (CFU) is the simplest method known to enumerate the bacteria and fungi in per ml or per g of liquid or solid sample respectively.

Colony Forming Unit (CFU)

In this method, serial dilutions of the following given sample having a viable microbial cell population are then spread on the respective solid growth medium. Then these plates will be incubated at the optimum temperature required by the respective bacteria and fungi. Three plates per sample are to be used in order to interpret the accurate result and reduce the percentage of error. It is presumed that each bacterial/fungal colony arises from an individual cell that has undergone multiple cell division. Therefore, by counting the number of colonies and accounting for the dilution factor, the number of bacteria/fungus in the original sample can be determined.

Material Required: Bacteria sample, Sterilize distilled water, Centrifuge tube, Inoculation loop, Vortex.

Procedure

1. Take 9.9 ml of sterilized distilled water in four 2 ml centrifuge tube and prepare serial dilution of 10^{-2} , 10^{-4} , 10^{-6} , and 10^{-8} , respectively.
2. Vortex the given sample to ensure an even distribution of bacteria/fungal cell. Remove 0.1 ml of sample with a sterile pipette and transfer it to the 10^{-2} dilution tube.
3. Vortex the 10^{-2} tube and transfer 0.1 ml to the 10^{-4} tube then again vortex the 10^{-4} dilution tube and transfer 0.1 ml to the 10^{-6} tube.
4. Vortex the 10^{-6} tube, transfer 0.1 ml to 10^{-8} tube and vortex again.
5. Vortex each centrifuge tube and then spread 100ul of each of these dilution on solid agar plate in triplicates with the help of glass spreader.

6. Glass spreader should be sterilized. Dip the glass spreader in 95% ethanol dipped and sterilized on flame and kept them for cool.
7. After spreading, allow the surface of the agar to dry and incubate them at 37°C for 2 days.

Calculation

$$\text{CFU/ml} = \frac{\text{Number of colonies on solid agar plate}}{\text{Volume of liquid spread on solid agar}} \times \text{Dilution factor}$$

Observation Table

Sample	Dilution	Plate 1	Plate 2	Plate 3
1	10 ⁻²			
	10 ⁻⁴			
	10 ⁻⁶			
	10 ⁻⁸			
2	10 ⁻²			
	10 ⁻⁴			
	10 ⁻⁶			
	10 ⁻⁸			
3	10 ⁻²			
	10 ⁻⁴			
	10 ⁻⁶			
	10 ⁻⁸			

Result: Given sample has number of bacteria and number of fungal colonies.

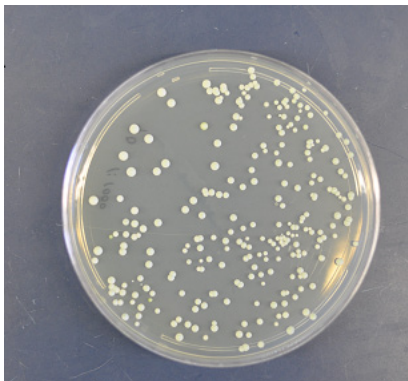

Bacterial Colonies on Solid Agar Plate

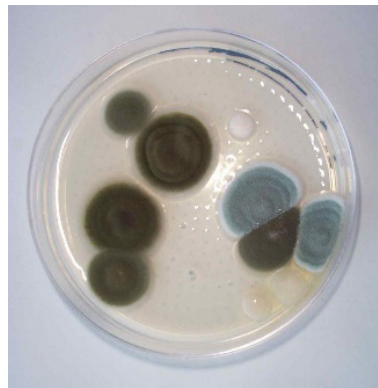

Fungal Colonies on Potato Dextrose Agar Plate

NOTES

NOTES

Experiment 2: Pure Culture and Preservation of Bacteria.

Objective: To study how to culture pure strain of bacteria and preserve it.

Theory

Microbial culture having only one kind of microorganism is called pure culture. Generally, the cultures obtained from nature are of mixed culture. They have more than one type of microorganisms present in them. Pure culture is helpful in order to study the morphological and physiological characteristic of any given microorganism. There are four different methods to obtain pure culture from the mixed culture.

- Streak Plate Method
- Spread Plate Method
- Pour Plate Method
- Micromanipulator Method

1. **Streak Plate Method:** In this method a sterilized loop of nichrome wire is dipped in the bacterial suspension and then streaked on the surface of solidified agar plate in a zigzag way. This process is repeated thrice to streak out the bacteria on the agar plate so that some individual bacteria are separated from each other. This method produce well separated colonies of bacteria from the concentrated suspension of bacterial cell.

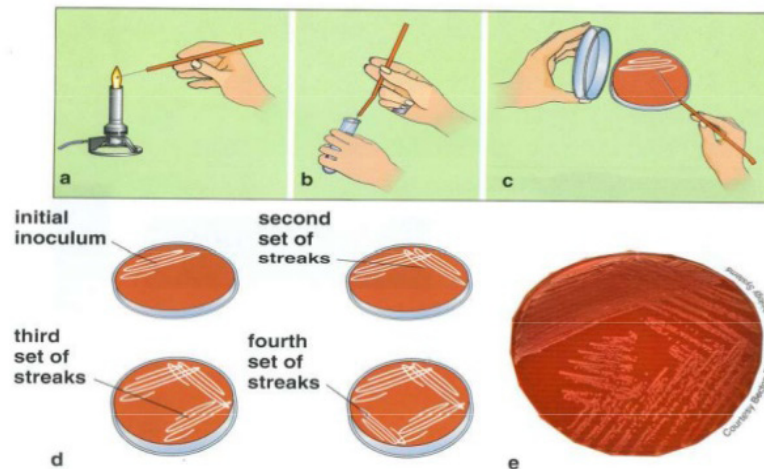

Streak Plate Technique (Quadrant Streak, Loop Dilution)

2. **Spread Plate Method:** In this method, small volume of dilute mix microbial culture is transferred to the solid agar plate and then it is spread with sterilized glass spreader on the solid agar plate. Incubate the agar plate at 37°C for 24 hours, in the inverted position. The dispersed cells will develop into isolated colonies.

3. **Pour Plate Method:** In this technique, serial dilution of the given inoculum were prepared. After this, 100ul from each inoculum were spread on solid agar plate and incubated at 37°C for 24 hours.

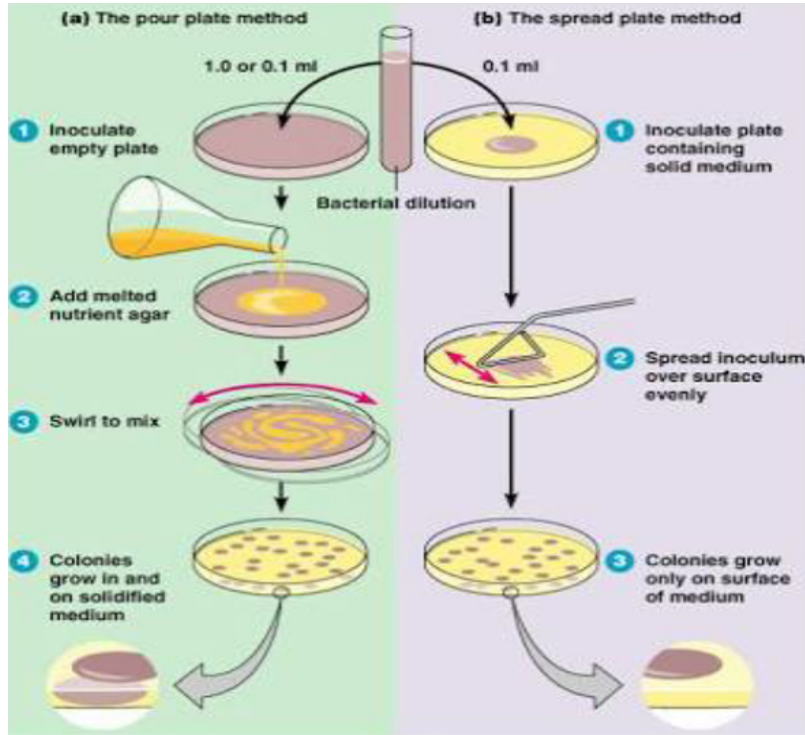

NOTES

4. **Micromanipulator Method:** In this technique, single colony of the given bacterial cell is picked out using a micromanipulator and transferred to the culture media. This culture media is incubated at 37°C for 24 hours.

Preservation of Bacteria

Pure culture of bacteria are to be preserved for a long period of time in order to study the morphological and physiological characteristics of these microorganisms. These preserved culture may be made available for the further study either in laboratory work or for the purpose of research work. Following are the four methods used for the maintenance and the preservation of pure culture.

1. **Refrigeration:** In this method overnight grown bacteria culture mix with sterile 70% liquid glycerol in 1:1 in a cryo vial and store at 0-4°C. Storage of microbial culture at low temperature slow down the metabolic activities of the microorganisms.
2. **Paraffin Method:** In this method, sterile liquid paraffin poured over the slant (slope) of bacterial culture and is kept upright at the room temperature. Paraffin creates the anaerobic conditions and prevents

NOTES

the dehydration of the microorganisms. This condition help microbes remain in dormant state. This is simple and economical method and can preserve the microbial culture for several years.

3. Cryopreservation: In this method microbial culture are rapidly frozen in liquid nitrogen at the temperature of -196°C in the presence of glycerol. Glycerol prevent the formation of ice crystal and also helps survival of microbes for long period of time.

4. Lyophilisation (Freeze-Drying): In this technique, microbial culture is rapidly frozen at a very low temperature (-70°C) and then dehydrated by vacuum. Metabolic activities of the microorganisms are stopped and then the microbes attain a dormant state and retain their viability for years. This is most frequently used technique by culture collection centres.

Experiment 3. Gram Staining - Positive and Negative Staining of Bacteria.

Objective: To study positive and negative gram staining of bacteria.

Principle

Gram staining was developed by a Danish physician, Hans Christian Gram in 1884. It is used to divide the bacteria in to two different groups, Gram Positive and Gram Negative Bacteria on the basis of chemical and physical the composition of their cell wall. In Gram Positive Bacteria, cell wall have a thick layer of peptidoglycan whereas gram negative have thin layer of peptidoglycan surrounded by lipid layer. In Gram Positive Bacteria, the pores in the cell wall becomes dehydrated and closed due to the alcohol treatment as they are comprised of the thick cell wall which is made up of protein and cross linked muco-peptide. The presence of thick cell wall prevents the loss of violet-iodine complex and thus the cells retain the primary stain and appear blue in colour. Whereas in case of Gram Negative Bacteria, lipid allows the leakage of crystal complex and cell wall then decolorizes and thus appear to be red in colour due to saffranin used as counter stain.

Procedure

1. Thin smear of the given bacterial sample was prepared on a clean glass slide and let them dry.
2. Heat fix the smear and kept it on slide rack for cool down.
3. Gently cover the smear with crystal violet for 1 minute and then wash with distilled water using wash bottle.
4. Again cover the smear with Gram's Iodine Solution for 1 minute and then again wash with distilled water.
5. Decolorized the smear with 95% alcohol and again wash the slide with distilled water and drain.

6. After this, saffranin was poured as a counter stain by using dropper and rest for 30 seconds.
7. After 30 seconds, wash the slide with distilled water and blot dried with absorbent paper.
8. The stained slides were air dried and observed under the microscope.

NOTES

Observation and Result

1. Examine the stained slides under microscope using oil immersion and classify the given Bacterial Culture.
2. Those Bacteria that appear blue are referred to as Gram Positive and those appearing pink are described as Gram Negative.

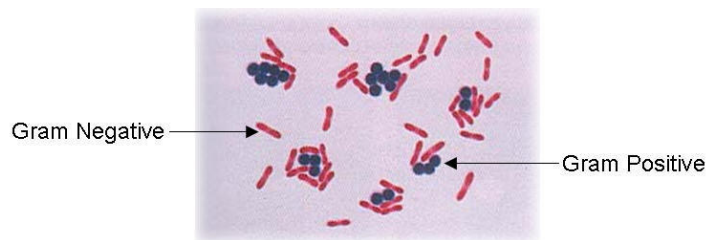

Experiment 4. Motility of Bacteria.

Objective

1. To study about the motility of living Bacteria and different methods in order to determine the motility.
2. To understand the biochemical processes, such as hydrogen sulfide production by Bacteria along with its motility.

Principle

Motility is the ability of Bacteria to move by itself. It is closely linked with chemotaxis, the ability to orient along a specific chemical. These Bacteria are capable to swim in the liquid medium. Motility is common among Spirilla and Bacilli but rare in coccal forms. Locomotory organs are small hair like appendages known as flagella. They are cytoplasmic in nature and about 120\AA - 150\AA thick and 4 or 5μ long. Each flagellum arises from a granule called a blepharoplast and passes out through the cell wall. On the basis of number and arrangements of flagella, Bacteria are classified into following two groups.

A. Polar Flagellation: This type of flagellation is generally observed in the case of Gram Negative Bacteria having Bacilli and Spirilla shape. This is further divide into four types as,

(a) Monotrichous: In this type, the bacterium cell bears only single flagellum with more than one curve. It is inserted at or near one pole of the cell.

NOTES

Example: All *Vibrios* are monotrichous.

(b) Amphitrichous: These Bacteria bear one flagellum on each pole.

Example: *Alcaligenes faecalis*.

(c) Cephalotrichous: In this type bacterium cell bear two or more flagella in a bunch at one pole of the bacterium cell. Flagellum shows more than two curves.

Example: *Pseudomonas fluoresces* (Rod-Shaped Bacterium)

(d) Lophotrichous: They bear two or more flagella at both the poles of the bacterium cell with one or two curves.

Example: *Spirillum volutans*.

B. Non-Polar Flagellation: Flagella are found all over the surface of the cell. They are also known as **Peritrichous** due to the even distribution of flagella over the cell surface.

Example: *Proteus vulgaris* and *Bacillus typhosus*.

Bacterial cells which lack flagella are non-motile and also known as **Atrichous**.

Example: *Diphtheria bacilli* and *Lacto bacillus*. Movement in these type of Bacteria is purely physical and is also known as Brownian movement.

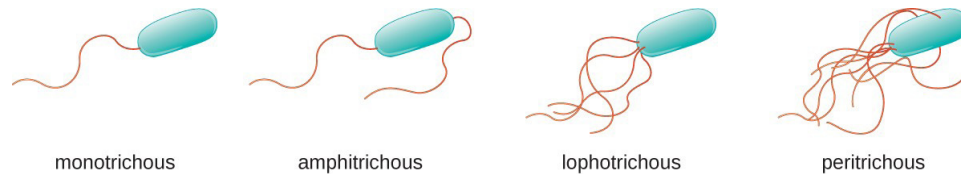

Motility Determination: There are two methods employed in order to determine the motility of Bacteria on the basis of their pathogenicity. In case of Pathogenic Bacteria, tube method can be used while in case of non-pathogenic slide method can be used.

I. Slide Methods for Non-Pathogens

1. **Wet Mount Slide:** In this method, place a lapful of bacterial culture on clear glass slide and cover it with a glass slip. This method is useful to determine movement as well as shape of the bacterial cell.
2. **Hanging Drop Slide:** In this technique, the slide is ground with a concave well in the center and the cover glass holds a drop of the suspension. When the cover glass is inverted over the well of the glass slide, the drop hangs from the glass in the hollow concavity of the slide. Since the drop lies within an enclosed glass chamber, drying out of bacterial cell occurs very slowly. Thus a ring of Vaseline around the edge of the cover slip keeps the slide from drying out. This method is useful to observe the shape and arrangement of bacterial cell.

NOTES

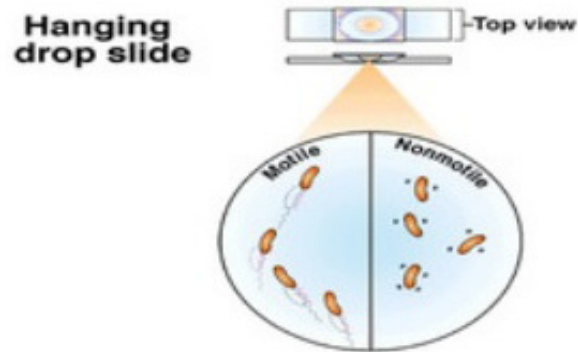
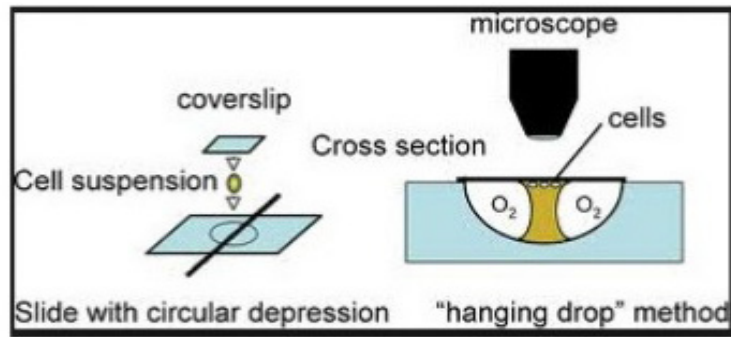

II. Tube Method for Pathogenic Microorganisms

This method is also known as Soft Agar Stabbing method. In this method, bacterial cells are inoculated in SIM (Sulphide Indole Motility) medium. Only the Non-Motile Bacteria will grow in SIM media whereas the motile ones will swim out from the stabbed area.

Procedure

1. Clean and dry the glass slide and cover slip. Place a thin film of petroleum jelly on glass slide.
2. Place the loopful of culture in the centre of the cover glass. Hold the hollow-ground slide inverted with the well down over the cover glass, and then press it down gently so that the petroleum jelly adheres to the cover glass.
3. Place the slide on the microscope stage with cover glass up. Using oil immersion. First examine the motility of bacterial cell under low power and then increase the power to focus the cell.
4. Record the observations of the size, shape, cell groups, and motility of the bacterial cells.
5. Discard your slides in a container with disinfectant solution.

NOTES

Observation and Result

The given sample of Bacteria show:

- Size
- Shape
- Motility

Experiment 5: Hydrolysis of Starch, Gelatin and Protein.

Objective: To study the ability of microorganism to hydrolyse the starch, gelatin and protein.

I. STARCH

Principle: It is a complex polysaccharide composed of amylose and amylopectin. Amylose is a straight chain polymer of 200-300 glucose units, and amylopectin is a group of larger branched polymer. In both amylose and amylopectin, α -D-glucose molecules are bonded by 1,4- α -glycosidic (acetal) linkages. While the side chain is bonded to carbon number 6 of the main chain therefore known as 1,6- α -glycosidic linkage. Structure of starch is too large to pass through the bacterial cell membrane; therefore, it must hydrolyse first in to small subunits of sugar like maltose and glucose. In laboratory experiment, the ability of microbes to hydrolyse starch determine by using iodine as indicator. In the presence of iodine; starch produces dark blue colouration on solid agar plate of selective medium. Dark blue colour appeared as iodine is trapped in the helical structure of starch and a clear zone occurs around the starch hydrolysing bacteria strain. This show the hydrolysis of starch into monosaccharide and indicate the amylolytic activity.

Material Required: Nutrient Agar media, Test organism, Petri plates, Inoculation loop.

Procedure

1. Preparation of nutrient agar media of composition nutrient agar - Distilled water – 1000 mL, pH-7.2.
2. Sterilize the prepared media at 121°C for 15 minutes at 15 lb/square inch and poured into pre-sterilized plates.
3. Streak the given sample of bacterial strain on solid agar plate and incubate at 37°C for 48 hours.
4. After incubation, wash the surface of agar plate with the iodine solution for 30 seconds. And pour off the excess iodine solution.

Observation and Result

1. Bacterial strain with a clear zone around its growth shows positive results and are able to hydrolyse starch.

2. Absence of clear zone around the growth of bacterial strain shows negative results and these Bacteria are not capable to hydrolyse starch.



Starch Hydrolysis Test

NOTES

GELATIN

Principle: It is a protein obtained by hydrolysis of collagen (animal protein), a compound of connective tissue and tendons in human. It is also used as a substrate for proteolytic enzymes. This test also indicates the presence of gelatinase, an extracellular proteolytic enzyme that hydrolyse gelatin. This enzyme hydrolyses the gelatin in to polypeptides and then these polypeptides were further converted into amino acids. Liquification of solid agar medium indicates the presence of gelatinase enzyme.

Material Required: Nutrient Gelatin Agar media, Test organism, Test tubes, Inoculation loop.

Procedure

1. Preparation of nutrient gelatin media of composition, Peptone – 5 g, Gelatin – 20 g, Beef extract – 3 g, Sodium chloride – 5 g, Distilled water – 1000 mL, pH–7.2.
2. Sterilize the prepared media at 121°C for 15 minutes at 15 lb/square inch and poured into pre-sterilized tubes.
3. Tubes are allowed to cool down and then they are inoculated with given bacterial strain with 1 inoculated tube used as a control.
4. Incubated the tubes at room temperature for 24 hours.

NOTES

Observation and Result

After 24 hours, keep the test tube on ice for half an hour and observe the liquefaction of gelatin.

Bacterial strain which showed the process of liquefaction are capable to hydrolyze gelatin while those that do not show the process of liquefaction are unable to hydrolyze gelatin.

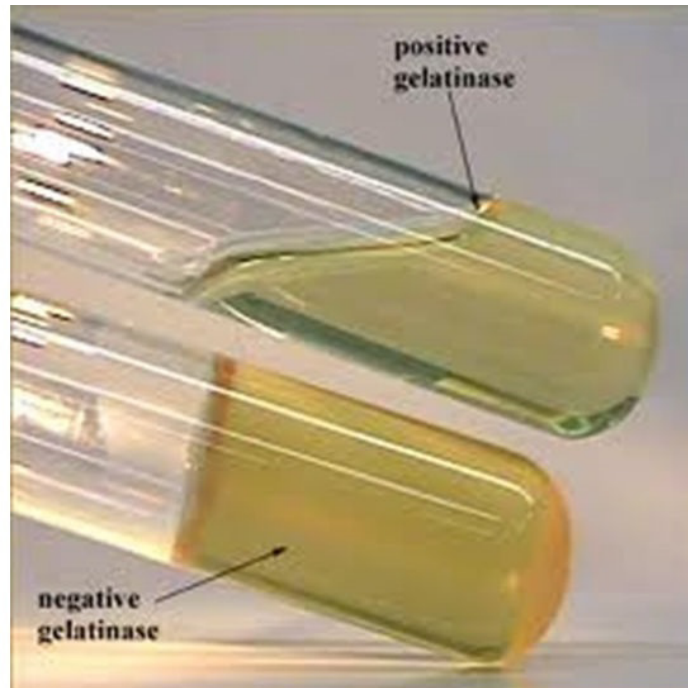

Gelatin Hydrolyse Test

PROTEIN (CASEIN)

Principal: It is macromolecule composed of amino acids which are linked together by peptide bond (CO-NH). It hydrolyse by a Proteolytic exo Enzyme called Proteinase which break the peptide bond. Appearance of clear zone around the bacterial strain streak on skim milk agar plate, indicates the presence of proteinase and also showed the hydrolysis of casein. During this reaction casein is converted in to small chain amino acids, dipeptides, and polypeptides.

Material Required: Skim Milk Agar media, Test organism, Pre-sterilize petri plates, Inoculation loop.

Procedure

1. Preparation of Skim Milk Agar medium of composition SM powder 28.0gm/L, Tryptone 5.0gm/L, Yeast extract 2.50gm/L, Dextrose (Glucose) 1.0gm/L, Agar 15.0gm/L, pH 7.5.

2. Sterilize the prepared media at 121°C for 15 minutes at 15 lb/square inch and pour into pre-sterilized petri plates.
3. Streak the given bacterial strain on the prepared plates and incubate at 37°C for 24 hours.

Observation and Result

Appearance of clear zone around the bacterial growth showed the presence of proteinase.

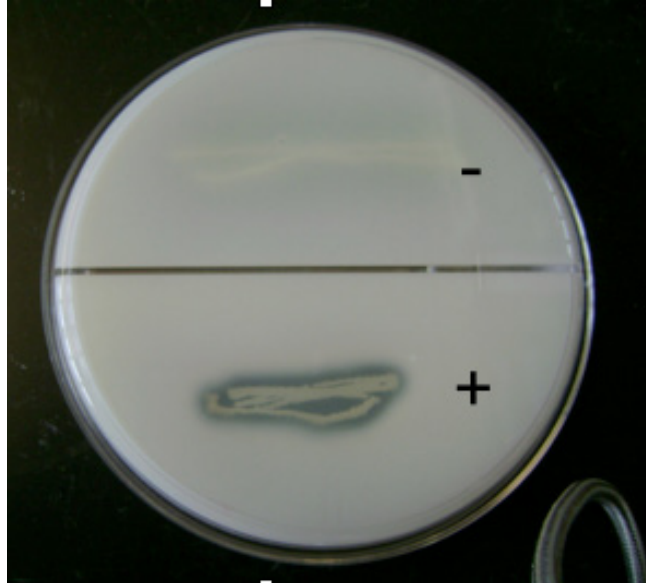

Casein Hydrolyse Test

Experiment. 6: Antibiotic Susceptibility Test.

Objective: To determine the susceptibility of a given bacterial culture to a range of antibiotics.

Principle

Antibiotics are natural antimicrobial substance produced by microorganisms. For example, Penicillin, produced by the mould *Penicillium notatum*. Disc diffusion method also known as Kirby-Bauer method is the most commonly used method to determine the susceptibility of a given microbe against the antibiotic. In this method, antimicrobics-impregnated paper discs are placed on a plate that is inoculated to form a bacterial lawn. The susceptibility of the given Bacterial Strain is observed on the basis of size of the clear zone appear around the disk and the point where MIC (Minimum Inhibitory Concentration) of antibiotic is reached.

Some antibiotics kill the Bacteria and are said to be Bactericidal whereas other which stop growth but do not kill the microbe are bacteriostatic.

NOTES

NOTES

Materials and Methods

Broth culture, Muller- Hinter Agar plates, Antibiotic disc, Cotton swab and Sterile forceps.

Procedure

1. The test organism was inoculated in a Luria Broth and then incubated at 37°C for 24 hours.
2. After 24 hours, 50 ul from the bacterial cell suspension was spread on Muller-Hinter Agar plates using sterile cotton swab and kept for few seconds to dry.
3. The antibiotic discs of known potency were placed on to agar surface using sterile forceps and pressed it gently.
4. Incubate the plates at 37°C for 12 hours and observed it carefully.

Observation and Result

Observed the zone of growth inhibition around the disc and measured it and compared the value with **Standard Antibiogram**. Based on the comparison the organism can be differentiated into **Sensitive, Intermediate Sensitive and Resistant**.



Antibiotic Susceptibility Test